

# ENERPAC®



POWERFUL SOLUTIONS. GLOBAL FORCE.



# BOLTING TOOLS

GB

E 4 1 4 e

**Enerpac's Bolting Solutions caters to the complete bolting work-flow, ensuring joint integrity in a variety of applications throughout industry:**

### Joint Assembly

From simple pipe alignment to complex joint positioning of large structural assemblies, our comprehensive line of joint assembly products range from hydraulic and mechanical alignment tools to PLC-controlled multi-point synchronous positioning systems.

### Controlled Tightening

Enerpac offers a variety of controlled tightening options to best meet the requirements of your application. From mechanical torque multipliers to hydraulic, pneumatic and electric driven square drive wrenches, and from low profile hexagon torque wrenches to inter-connectable bolt tensioning tools; we offer the products you need for accurate and simultaneous tightening of multiple bolts.

### Joint Separation

Enerpac also provides hydraulic nut splitters and a variety of mechanical and hydraulic spreading tools for joint separation during inspection, maintenance and decommissioning operations. High quality bolting solutions from the brand you can trust. See how Enerpac can make your bolting work-flow more accurate, safer and efficient.





































### Bolting Integrity Software

Visit [www.enerpac.com](http://www.enerpac.com) to access our free on-line bolting software application and obtain information on tool selection, bolt load calculations and tool pressure settings. A combined application data sheet and joint completion report is also available.



[www.enerpac.com](http://www.enerpac.com)

# Bolting Tools Overview

Tool Type and Functions	Series		Page
<b>INTRODUCTION AND CAPABILITIES</b>			
Bolting Solutions – Product Range Overview			2 ▶
<b>CONTROLLED TIGHTENING AND LOOSENING</b>			
<b>Torque Tools</b>			
• Manual Torque Wrench Multipliers	E		4 ▶
• Hydraulic Square Drive Wrenches and Accessories, Steel	S		6 ▶
• Heavy-Duty Impact Sockets	BSH		10 ▶
• Hydraulic Hexagon Wrenches and Accessories, Steel	W		12 ▶
• UltraSlim Bi-Hexagonal Stepped Width Cassettes	W-SL		22 ▶
• Roller Cassette Torque Wrench, Bi-Hexagonal	WCR		24 ▶
• Hydraulic Square Drive Wrenches, Aluminium	SQD		26 ▶
• Hydraulic Hexagon Cassette Wrenches, Aluminium	HXD		30 ▶
• Pneumatic Torque Wrenches	PTW		34 ▶
• Electric Torque Wrenches	ETW		36 ▶
<b>Torque Wrench Pumps</b>			
• Selection Matrix Pumps - Wrenches - Hoses	PME, PMU		40 ▶
• Portable Electric Torque Wrench Pump, universal motor	ZU4T		41 ▶
• Electric Torque Wrench Pumps, universal motor	ZE4T, ZE5T		42 ▶
• Electric Torque Wrench Pumps, induction motor	TQ		46 ▶
• Electric Torque Wrench Pumps, induction motor	PTA		48 ▶
• Compact Pneumatic Torque Wrench Pumps	ZA4T		50 ▶
• Air Driven Torque Wrench Pumps			52 ▶
<b>Tensioning Tools &amp; Pumps</b>			
• Hydraulic Bolt Tensioners	GT		56 ▶
• Electric Pumps, universal motor	ZUTP		58 ▶
• Portable Hand Pump, Hoses and Couplers	HPT, HT, B		59 ▶
• Air Pump	ATP		60 ▶
<b>JOINT ASSEMBLY AND POSITIONING</b>			
Power Box - Portable Tool Sets	SC, SL, SR		61 ▶
Cylinder-Pump Sets	SCH, SCR		62 ▶
Flange Alignment Tools	ATM		64 ▶
<b>JOINT SEPARATION</b>			
Hydraulic Nut Cutters, single and dual blade models	NC, NC-D		65 ▶
Hydraulic Nut Splitters	NS		66 ▶
Hydraulic Flange Spreaders	FS		68 ▶
Parallel Wedge Spreaders	FSH, FSM		69 ▶
Hydraulic Wedgie and Spread Cylinders	A, WR		70 ▶
Mechanical Flange Face Tool "QuickFace"	FF		71 ▶
<b>YELLOW PAGES, TECHNICAL INFORMATION</b>			
Bolting Solution and Application Worksheet			73 ▶
Safety Instructions			74 ▶
Bolting Theory			76 ▶
Torque Tightening			78 ▶
Tensioning			80 ▶
Hexagon Nut and Bolt Sizes, Key to Measurement			82 ▶
Pressure versus Torque S and W-Series Torque Wrenches			84 ▶

## ATM-Series, Flange Alignment Tools



### Misaligned joints

Joints must be pulled together and correctly aligned prior to tightening. Current methods of manipulation tend to be dangerous and involve a high degree of manual lifting using slings, hooks and lifting gear. These methods can damage joint components, are time consuming in setup and disassembly, operational time and the amount of manpower required.

### Solution: Flange Alignment Tools

The Enerpac ATM-Series Flange Alignment Tools are developed to rectify twist and rotational misalignment without additional stress in pipelines. Hydraulic cylinders, jacks and lifting wedges can also be used to assist in positioning and aligning.

## E-Series, Manual Torque Multipliers



### Controlled tightening when external power is unavailable

Applications are often located where external power sources to drive air or electric powered tools are unavailable but controlled bolting is required, typically at values higher than an operator can generate using manual wrenches.

### Solution: Manual Torque Multipliers

Enerpac E-Series manual torque multipliers offer a range of output torques from manual inputs that can easily be achieved by an operator, providing accurate, efficient torque multiplication for make-up or break-out of joint fasteners.

## S and W-Series, Torque Wrenches



### Industrial Applications

Controlled tightening of multiple sized fasteners for industrial applications.

### Solution: Hydraulic Torque Wrenches

Enerpac hydraulic torque wrenches are professional tools for industrial applications. Truly versatile tools which utilize standard Impact Sockets, optional direct Allen-Key Drives or interchangeable hexagon cassettes to provide controlled tightening of multiple sized fasteners per tool. Optional accessories further extend the application range of these products.

## PTW and ETW-Series, Torque Wrenches



### General Applications

Applications that require controlled bolting, feature a high volume of fastenings.

### Solution: Pneumatic and Electric Torque Wrenches

Enerpac PTW-Series pneumatic torque wrenches are fast, easy to use and highly accurate. Enerpac ETW-Series electric torque wrenches are particularly well suited for complex jobs, which demand precision and traceability.

## Controlled Bolting

Increasing Health and Safety, Environmental and Productivity requirements demand even and parallel joint closure to ensure a sound assembly, especially on pressure containing vessels. This often requires the simultaneous tightening of multiple fasteners.

## Solution: Hydraulic Bolt Tensioners

Enerpac GT-Series Bolt Tensioners can achieve accurate preload in single or multiple fastener applications simultaneously, without inducing rotational twist or contending with the uncertainties of friction and lubrication.

## GT-Series, Bolt Tensioners



## Frozen or Corroded Nuts

Often nuts are difficult to remove, while loosening using tightening tools is possible, it generally requires larger equipment and is time consuming. The use of cutting torches or hammers and chisels can cause damage to the joint components, requires significantly longer setup and operational time, and can present a potential safety risk.

## Solution: Hydraulic Nut Cutters

Nut splitting with the NC and NS-Series Hydraulic Nut Cutters is the safest method. It takes less time and avoids costly damage to joint components. The head design fitted with heavy-duty chisels permits the splitting of nuts on a wide variety of applications. With the two blades models nuts are split from two side in one action.

## NC and NS-Series, Nut Cutters



## Joint Separation

Separation of stubborn joints for inspection and maintenance, particularly those fitted with ring grooves or those with external forces acting on them are often difficult to separate. The use of hammers and wedges, chain blocks and lever bars can damage joint components and present a potential safety risk.

## Solution: Parallel Wedge Spreaders

The FSH, FSM-Series parallel wedge spreaders offer controlled separation without bending or risk of slipping from the joint. The FS-Series spreaders are ideally suited to flanged joint applications.

## FSH, FSM-Series, Wedge Spreaders



## Pumps and Accessories

A wide range of pumps and accessories are available including: manual, air and electrically operated pump units, hoses, gauges, manifolds and fittings.

## Pumps and Accessories



▼ Shown from left to right: E291, E393, E494



- High-efficiency planetary gear sets achieve high output torque from low input torque
- Most models operator protected by anti-backlash device
- Multiplier output accuracy  $\pm 5\%$  of input torque
- Reversible, tighten or loosen bolts
- Reaction bar or reaction plate type
- Angle-of-turn protractor standard on E300 models
- Reaction plate models offer increased versatility with reaction point locations
- E300 and E400 series replaceable shear drives provide overload protection of internal power train (one replacement shear drive is included).

## Accurate, Efficient Torque Multiplication

When accurate make-up or break-out of stubborn fasteners requires high torque



### Typical Torque Multiplier Applications

- Locomotives
- Power plants
- Pulp and paper mills
- Refineries
- Chemical plants
- Mining and construction
- Off-road equipment
- Shipyards
- Cranes.



### Heavy Duty Sockets

Use only Heavy Duty Impact Sockets for power driven torquing equipment, according to ISO2725 and ISO1174; DIN3129 and DIN3121 or ASME-B107.2/1995.

Page: **10**

### ▼ SELECTION CHART

Torque Multiplier Type	Output Torque Capacity		Model Number
	(Nm)	(Ft.lbs)	
Reaction Bar Multiplier	1015	750	E290PLUS
	1355	1000	E291
	1625	1200	E391
	2980	2200	E392
	4340	3200	E393
Reaction Plate Multiplier	2980	2200	E492
	4340	3200	E493
	6780	5000	E494
	10.845	8000	E495

# Manual Torque Multipliers



## Manual Torque Multipliers

Enerpac manual torque multipliers provide efficient torque multiplication in wide clearance applications and when external power sources are not available.

Manual torque multipliers are used in most industrial, construction, and equipment maintenance applications. Hydraulic torque wrenches are better suited for tight tolerance, flange and repetitive bolting applications.

## Use Reaction Bar Models:

- where space is limited
- where multiple reaction points are available
- when portability is desirable.

## Use Reaction Plate Models:

- above 3.200 Nm output torque
- on flanges and applications where neighboring bolt or nut is available to react against
- when extreme reaction forces are generated.

## E Series



Maximum Output Torque:

**1015 - 10.845 Nm**

Torque Ratio:

**3:1 - 52:1**

Multiplier Output Ratio Accuracy:

**± 5 %**

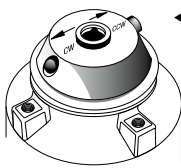

### Selector Pawl

Models with anti-backlash protection have directional selector pawls. Set the pawl for clockwise or counter-clockwise rotation.

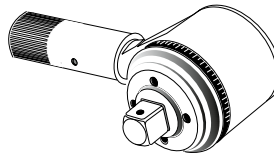

### Angle-of-Turn Protractor

E391, E392 and E393 models include an angle-of-turn protractor (scale) to tighten fasteners using a "torque turn" method. Allows accurate measuring of a specific number of degrees of rotation.

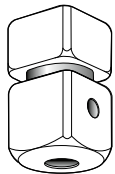

### Shearable Square Drive

Provides overload protection on E300- and E400-series multiplier's power train by shearing at 103-110% of rated capacity. Internal shear pin prevents tool from falling off bolt.



### CAUTION!

Never use impact type air tools for power driving torque multipliers. Torque multiplier drive train damage will occur.

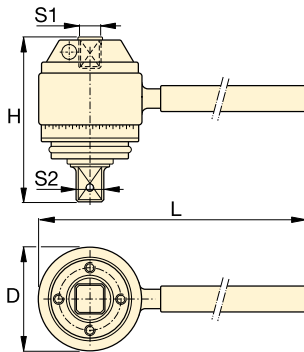

Reaction Bar Type <sup>1)</sup>

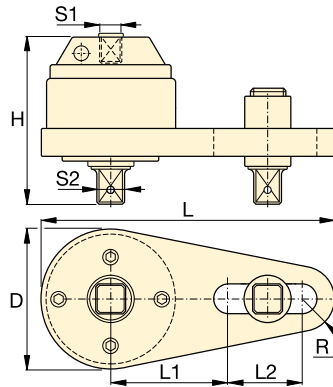

Reaction Plate Type <sup>1)</sup>



## Hydraulic Torque Wrenches

Enerpac offers a complete range of square drive and hexagon cassette torque wrenches.

Page: 1

Input Torque		Torque Ratio	Input Female Square Drive S1 (inch)	Output Male Square Drive		Overload Protection	Anti-Backlash	Dimensions (mm)						Model Number	
(Nm)	(Ft.lbs)			S2 (inch)	Replaceable Shear Drive Model No.			D	H	L	L1	L2	R		
338	250	3 : 1	1/2	3/4	—	No	No	71	84	218	—	—	—	1,8	E290PLUS
451	333	3 : 1	1/2	3/4	—	No	No	71	84	442	—	—	—	2,5	E291
271	200	6 : 1	1/2	3/4	E391SDK	Yes	No	100	102	498	—	—	—	4,1	E391
220	162	13,6 : 1	1/2	1	E392SDK	Yes	Yes	103	146	498	—	—	—	6,9	E392
235	173	18,5 : 1	1/2	1	E393SDK	Yes	Yes	103	165	498	—	—	—	8,3	E393
220	162	13,6 : 1	1/2	1	E392SDK	Yes	Yes	124	140	356	140	124	32	7,8	E492
235	173	18,5 : 1	1/2	1	E393SDK	Yes	Yes	124	163	356	140	124	32	8,9	E493
256	189	26,5 : 1	1/2	1 1/2	E494SDK	Yes	Yes	143	222	378	178	89	41	15,4	E494
209	154	52 : 1	1/2	1 1/2	E495SDK	Yes	Yes	148	293	387	178	89	48	22,8	E495

<sup>1)</sup> E200 and E400-series do not have an Angle-of-Turn Protractor (scale).

User must verify manual torque wrench accuracy prior to use to ensure accurate final output torque.

▼ Shown: S3000X



## Setting New Standards in Safety, Simplicity and Performance

### Safety and Performance

- Compact, high-strength uni-body construction provides a small operating radius without sacrificing endurance
- 35° rotation angle and rapid return stroke for fast operation
- Tough manifold design with added safety feature for enhanced operator safety

### Simplicity

- 360° click-on reaction arm with quick release lever provides easier handling, even with gloves on
- Includes robust handle which mounts on both sides of tool for extra maneuverability
- Push button square drive release for quickly reversing the square drive for tightening or loosening

### Versatility

- Available with optional enhanced tilt and swivel TSP300 manifold for horizontal and vertical maneuverability, with greater durability <sup>1)</sup>

### Accuracy

- Constant torque output provides accuracy of  $\pm 3\%$  across full stroke
- Optional Angle-of-Turn Indicator provides measurement of rotation.



### Two Handle Styles

Robust angled positioning handle comes standard with every S-Series (X-Edition) tool. Straight positioning handles are available

as accessories.

Compatible S-Series (X-Edition) wrenches	Model Nr. Angled positioning handles (standard)	Model Nr. Straight positioning handles (optional)
S1500X, S3000X	<b>SWH6A</b>	<b>SWH6S</b>
S6000X, S11000X	<b>SWH10A</b>	<b>SWH10S</b>
S25000X	<b>SWH10EA</b> <sup>2)</sup>	

<sup>2)</sup> SWH10EA is an eyebolt handle.



### TSP - Pro Series Swivel

The optional tilt and swivel manifold with robust interlocking design provides 360° X-axis rotation and 160° Y-axis rotation.

### How to Order <sup>1)</sup>

Factory fitted to S-Series (X-Edition) wrenches: Insert a "P" prior to the "X" in the tool model number, example: **S1500PX**.

Order as an accessory using the model number: **TSP300**, which can be fitted to existing S-Series (X-Edition) wrenches. Includes male and female couplers.

Page: **9**



### ATEX declared. Calibration certificate included.

All X-edition tools are CE - ATEX declared and are shipped complete with a calibration certificate.



<sup>1)</sup> TSP300 is designed for X-Edition tools only, and is not compatible with standard edition tools. For replacement components for existing tools, refer to repair sheet on [www.enerpac.com](http://www.enerpac.com)



# X-Edition, Square Drive Torque Wrenches

Standard are: ① ② ⑥ ⑧  
Other items are optional.

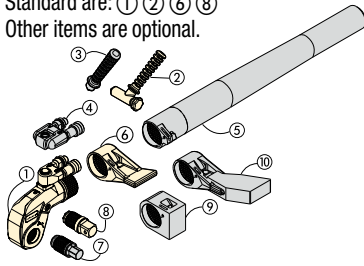

- ① Drive Unit
- ② Angeled Positioning Handle
- ③ Straight Positioning Handle
- ④ Pro Series Swivel
- ⑤ Reaction Tube Extension
- ⑥ Standard Reaction Arm
- ⑦ Allen Drive
- ⑧ Square Drive
- ⑨ Short Reaction Arm
- ⑩ Extended Reaction Arm

**Select the Right Torque**  
Choose your Enerpac Torque Wrench using the untightening rule of thumb:  
Loosening torque equals about 250% of tightening torque.

## S Series X-Edition



Maximum Torque Output:  
**35.455 Nm**

Square Drive Range:  
**3/4 - 2 1/2 inch**

Nose Radius:  
**25 - 64 mm**

Maximum Operating Pressure:  
**690 bar**

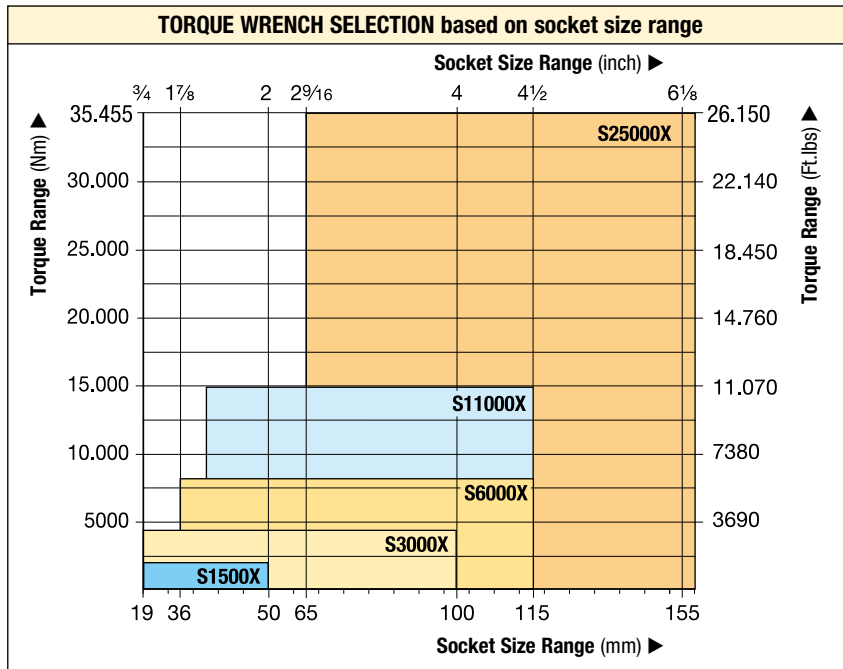

### Accessory Options

A full list of optional accessories is available for maximum versatility.

Page: 9

▼ The rigid steel design of the S-Series torque wrenches provides durability, reliability and safety.



**Use only Heavy Duty Impact Sockets**  
For power driven torquing equipment, according to ISO2725 and ISO1174; DIN 3129 and DIN 3121 or ASME-B107.2/1995.

Page: 10

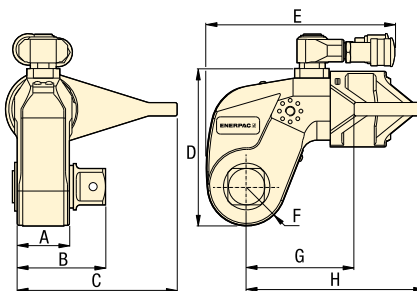

Nominal Torque at 690 bar		Minimum Torque at 69 bar		Square Drive Size (inch)	Model Nr. (included with wrench)	Angle-of-Turn Indicator Model Nr. (optional)	Torque Wrench Model Number <sup>2)</sup>	Dimensions (mm)								(kg)
(Nm)	(Ft.lbs)	(Nm)	(Ft.lbs)					A	B	C	D	E	F	G	H	
1952	1440	195	144	3/4	SD15-012	AOT15	<b>S1500X</b>	39	65	108	97	136	25	70	129	3,2
4373	3225	438	323	1	SD30-100	AOT30	<b>S3000X</b>	48	78	135	128	173	33	90	161	5,6
8338	6150	834	615	1 1/2	SD60-108	AOT60	<b>S6000X</b>	55	92	169	157	192	40	110	188	9,2
15.151	11.175	1516	1118	1 1/2	SD110-108	AOT110	<b>S11000X</b>	72	114	197	190	228	50	133	229	15,8
35.455	26.150	3545	2615	2 1/2	SD250-208	AOT250	<b>S25000X</b>	89	143	246	244	287	64	182	295	32,2

<sup>2)</sup> To order a S-Series (X-edition) torque wrench fitted with a TSP300 tilt and swivel manifold, insert a "P" prior to the "X" in the tool model number, example: **S1500PX**. See page 84 for pressure versus torque charts.

# SDA-Series, Allen Key Drives

Maximum Torque at 690 bar:

**35.455 Nm**

Square Drive Range:

**3/4 - 2 1/2 inch**

Hexagon Size Allen Drive:

**14 - 85 mm | 1/2 - 2 1/4"**

For  
**S-Series**  
**X-Edition**

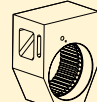
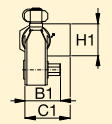

▼ **SELECTION CHART**

TORQUE WRENCH	OPTIONAL ALLEN DRIVES, IMPERIAL				OPTIONAL ALLEN DRIVES, METRIC				SHORT REACTION ARM FOR ALLEN DRIVES			
	Model Number	Hexagon Size (inch)	Maximum Torque (Nm)	Model Number	Dim. B1 (mm)	Hexagon Size (mm)	Maximum Torque (Nm)	Model Number	Dim. B1 (mm)	Model Number	Dimensions (mm) C1   H1	
 <b>S1500X</b> (1952 Nm)		1/2	481	SDA15-008	66	14	644	SDA15-14	66	  <b>SRA15X</b>	67,5	65
		5/8	936	SDA15-010	67	17	1152	SDA15-17	68			
		3/4	1620	SDA15-012	71	19	1607	SDA15-19	70			
		7/8	1952	SDA15-014	74	22	1952	SDA15-22	73			
		1	1952	SDA15-100	77	24	1952	SDA15-24	74			
<b>S3000X</b> (4373 Nm)		5/8	936	SDA30-010	77	17	1152	SDA30-17	77	<b>SRA30X</b>	80,0	74
		3/4	1620	SDA30-012	80	19	1607	SDA30-19	79			
		7/8	2569	SDA30-014	83	22	2488	SDA30-22	82			
		1	3830	SDA30-100	86	24	3234	SDA30-24	84			
		1 1/8	4373	SDA30-102	88	27	4373	SDA30-27	85			
		1 1/4	4373	SDA30-104	89	30	4373	SDA30-30	87			
		-	-	-	-	32	4373	SDA30-32	88			
<b>S6000X</b> (8338 Nm)		5/8	936	SDA60-010	85	17	1152	SDA60-17	86	<b>SRA60X</b>	91,5	89
		3/4	1620	SDA60-012	89	19	1607	SDA60-19	88			
		7/8	2569	SDA60-014	92	22	2488	SDA60-22	91			
		1	3830	SDA60-100	95	24	3234	SDA60-24	93			
		1 1/8	5457	SDA60-102	97	27	4603	SDA60-27	94			
		1 1/4	7484	SDA60-104	98	30	6311	SDA60-30	96			
		-	-	-	-	32	7660	SDA60-32	97			
<b>S11000X</b> (15.151 Nm)		1 1/4	7484	SDA110-104	115	30	6311	SDA110-30	112	<b>SRA110X</b>	127,5	106
		1 3/8	9958	SDA110-106	117	32	7660	SDA110-32	114			
		1 1/2	12.928	SDA110-108	118	36	10.901	SDA110-36	117			
		1 5/8	15.151	SDA110-110	122	41	15.151	SDA110-41	121			
		1 3/4	15.151	SDA110-112	125	46	15.151	SDA110-46	127			
<b>S25000X</b> (35.455 Nm)		1 1/2	12.928	SDA250-108	141	36	10.901	SDA250-36	140	<b>SRA250X</b>	158,5	135
		1 5/8	16.433	SDA250-110	145	41	16.107	SDA250-41	144			
		1 3/4	20.520	SDA250-112	148	46	22.744	SDA250-46	148			
		1 7/8	25.245	SDA250-114	149	50	29.211	SDA250-50	151			
		2	30.635	SDA250-200	151	55	35.455	SDA250-55	154			
		2 1/4	35.455	SDA250-204	154	60	35.455	SDA250-60	158			
		-	-	-	-	65	35.455	SDA250-65	161			
		-	-	-	-	70	35.455	SDA250-70	164			
		-	-	-	-	75	35.455	SDA250-75	168			
		-	-	-	-	85	35.455	SDA250-85	175			

# Accessories for S-Series Torque Wrenches

## Short Reaction Arms for use with Allen-Key Drives

Model Number	SRA15X	SRA30X	SRA60X	SRA110X	SRA250X
C1 (mm)	67,5	80,0	91,5	127,5	158,5
H1 (mm)	74,0	74,0	89,0	106,0	135,0

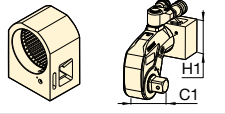

**RTEX  
SRAX  
SRSX  
TSP  
Series**



## TSP-Series, Pro Series Swivel

- Robust interlocking design
- 360° X-axis and 160° Y-axis rotation
- Increases tool fit in restricted access areas
- Simplifies hose placement
- Includes male and female couplers

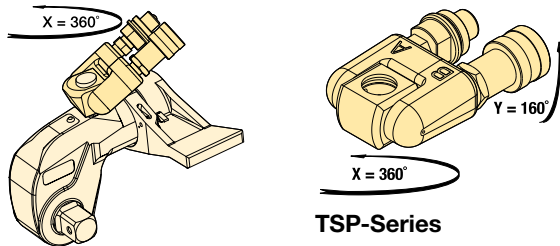

For Torque Wrench Model Number	Model Number <sup>1)</sup>	Maximum Pressure (bar)	Weight (kg)
S1500X, S3000X, S6000X, S11000X, S25000X	<b>TSP300</b>	690	0,2

<sup>1)</sup> To order a S-Series (X-edition) torque wrench fitted with a TSP300 tilt and swivel manifold, insert a "P" prior to the "X" in the tool model number, example: **S1500PX**. TSP300 is designed for X-Edition tools only, and is not compatible with standard edition tools. For replacement components for existing tools, refer to repair sheet on [enerpac.com](http://enerpac.com)

## RTEX-Series, Reaction Tube Extensions

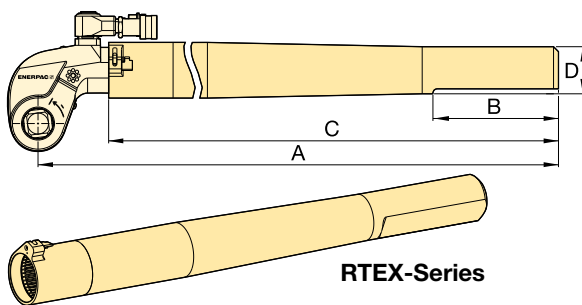

- Full torque rated
- Increases tool fit in restricted access areas

For Torque Wrench Model Number	Model Number	Dimensions (mm)				Weight (kg) *
		A	B	C	D	
S1500X	<b>RTE15X</b>	706	152	636	58	4,6
S3000X	<b>RTE30X</b>	733	152	647	57	5,5
S6000X	<b>RTE60X</b>	747	152	659	65	7,7
S11000X	<b>RTE110X</b>	769	152	675	76	11,2
S25000X	<b>RTE250X</b>	813	152	685	100	17,3

\* Weights indicated are for the accessories only and do not include the wrench.

## SRSX-Series, Extended Reaction Arms

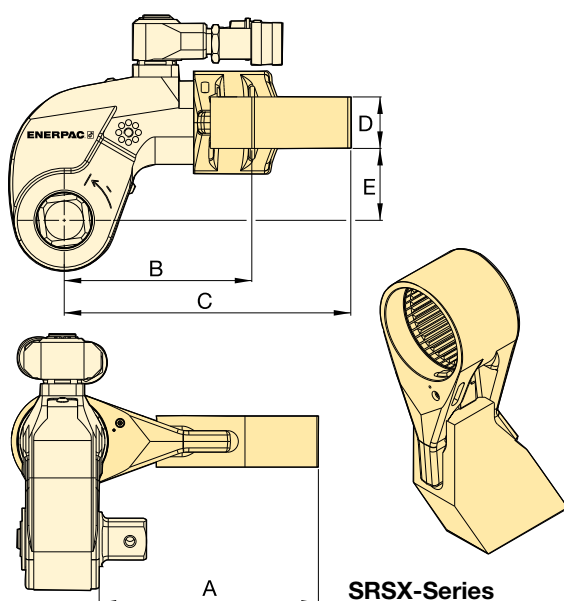

- Lightweight interchangeable design

For Wrench Model	Max. Torque (Nm)	Model Number	Dimensions (mm)					Weight (kg) *
			A	B	C	D	E	
S1500X	1801	<b>SRS151X</b>	94	86	127	24	34	0,8
	1641	<b>SRS152X</b>	119	97	138	24	34	1,0
	1533	<b>SRS153X</b>	145	109	148	24	34	1,2
S3000X	3918	<b>SRS301X</b>	111	106	168	34	48	1,6
	3712	<b>SRS302X</b>	137	117	182	34	48	2,0
	3574	<b>SRS303X</b>	162	132	198	34	48	2,5
S6000X	7842	<b>SRS601X</b>	138	128	192	39	62	2,3
	7454	<b>SRS602X</b>	163	144	207	39	62	2,7
	7175	<b>SRS603X</b>	189	159	222	39	62	3,4
S11000X	14.650	<b>SRS1101X</b>	149	157	232	46	76	4,4
	13.957	<b>SRS1102X</b>	175	172	247	46	76	5,1
	13.391	<b>SRS1103X</b>	200	187	261	46	76	5,8
S25000X	33.538	<b>SRS2501X</b>	183	209	295	50	100	7,6
	32.049	<b>SRS2502X</b>	208	222	310	50	100	8,4
	30.750	<b>SRS2503X</b>	233	236	326	50	100	10,0

\* Weights indicated are for the accessories only and do not include the wrench.

# BSH-Series, Heavy-Duty Sockets

- Heavy-duty impact sockets
- Supplied with "Pin and Ring"

METRIC SOCKETS							
¾" Square Drive		1" Square Drive		1½" Square Drive		2½" Square Drive	
Model Number	A/F (mm)	Model Number	A/F (mm)	Model Number	A/F (mm)	Model Number	A/F (mm)
BSH7519	19	BSH1019	19	BSH1536	36	BSH2565	65
BSH7524	24	BSH1024	24	BSH15163	41	BSH2570	70
BSH7527	27	BSH1027	27	BSH1546	46	BSH2575	75
BSH7530	30	BSH1030	30	BSH1550	50	BSH2580	80
BSH7532	32	BSH1032	32	BSH1555	55	BSH2585	85
BSH7536	36	BSH1036	36	BSH1560	60	BSH2590	90
BSH75163	41	BSH10163	41	BSH1565	65	BSH2595	95
BSH7546	46	BSH1046	46	BSH1570	70	BSH25100	100
BSH7550	50	BSH1050	50	BSH1575	75	BSH25105	105
-	-	BSH1055	55	BSH1580	80	BSH25110	110
-	-	BSH1060	60	BSH1585	85	BSH25115	115
-	-	BSH1065	65	BSH1590	90	BSH25120	120
-	-	BSH1070	70	BSH1595	95	BSH25125	125
-	-	BSH1075	75	BSH15100	100	BSH25135	135
-	-	BSH1080	80	BSH15105	105	BSH25140	140
-	-	BSH1085	85	BSH15110	110	BSH25145	145
-	-	BSH1090	90	BSH15115	115	BSH25150	150
-	-	BSH1095	95	-	-	BSH25155	155
-	-	BSH10100	100	-	-	-	-

## BSH Series



Hexagon Size:

**19 - 155 mm, ¾" - 6 ⅛"**



### Select the Right Torque

Choose your Enerpac Torque Wrench using the untightening rule of thumb: Loosening torque equals about 250% of tightening torque.

Page: 79

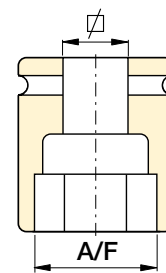

### Hexagon Bolt and Nut Sizes

See the table of hexagon sizes of bolts, nuts and related thread diameters.

Page: 82

IMPERIAL SOCKETS													
¾" Square Drive		1" Square Drive				1½" Square Drive				2½" Square Drive			
Model Number	A/F (inch)	Model Number	A/F (inch)	Model Number	A/F (inch)	Model Number	A/F (inch)	Model Number	A/F (inch)	Model Number	A/F (inch)	Model Number	A/F (inch)
BSH7519	¾"	BSH1019	¾"	BSH10231	2 5/16"	BSH15144	1 7/16"	BSH15281	2 13/16"	BSH25244	2 7/16"	BSH25419	4 3/16"
BSH75088	7/8"	BSH10088	7/8"	BSH10238	2 3/8"	BSH1538	1 1/2"	BSH15288	2 7/8"	BSH25250	2 1/2"	BSH25425	4 1/4"
BSH75094	15/16"	BSH10094	15/16"	BSH10244	2 7/16"	BSH15156	1 9/16"	BSH1575	2 15/16"	BSH2565	2 13/16"	BSH25110	4 5/16"
BSH7527	1 1/16"	BSH1027	1 1/16"	BSH10250	2 1/2"	BSH15163	1 5/8"	BSH15300	3"	BSH25263	2 5/8"	BSH25438	4 3/8"
BSH7530	1 3/16"	BSH1030	1 3/16"	BSH1065	2 9/16"	BSH1543	1 11/16"	BSH15306	3 1/16"	BSH25269	2 11/16"	BSH25450	4 1/2"
BSH75125	1 ¼"	BSH10125	1 ¼"	BSH10263	2 5/8"	BSH15175	1 ¾"	BSH15313	3 1/8"	BSH2570	2 ¾"	BSH25463	4 5/8"
BSH75131	1 5/16"	BSH10131	1 5/16"	BSH10269	2 11/16"	BSH1546	1 13/16"	BSH15319	3 3/16"	BSH25281	2 11/16"	BSH25475	4 ¾"
BSH7535	1 3/8"	BSH1035	1 3/8"	BSH1070	2 ¾"	BSH15188	1 7/8"	BSH15325	3 ¼"	BSH25288	2 7/8"	BSH25488	4 7/8"
BSH75144	1 7/16"	BSH10144	1 7/16"	BSH10281	2 13/16"	BSH15194	1 15/16"	BSH15338	3 3/8"	BSH2575	2 15/16"	BSH25500	5"
BSH7538	1 ½"	BSH1038	1 ½"	BSH10288	2 7/8"	BSH15200	2"	BSH15350	3 1/2"	BSH25300	3"	BSH25513	5 1/8"
BSH75156	1 9/16"	BSH10156	1 9/16"	BSH1075	2 15/16"	BSH15206	2 1/16"	BSH15363	3 5/8"	BSH25306	3 1/16"	BSH25519	5 3/16"
BSH75163	1 5/8"	BSH10163	1 5/8"	BSH10300	3"	BSH15213	2 1/8"	BSH1595	3 ¾"	BSH25313	3 1/8"	BSH25525	5 1/4"
BSH7543	1 11/16"	BSH1043	1 11/16"	BSH10306	3 1/16"	BSH15219	2 3/16"	BSH15388	3 7/8"	BSH25319	3 3/16"	BSH25538	5 3/8"
BSH75175	1 ¾"	BSH10175	1 ¾"	BSH10313	3 1/8"	BSH15225	2 ¼"	BSH15100	3 15/16"	BSH25325	3 ¼"	BSH25140	5 1/2"
BSH7546	1 3/16"	BSH1046	1 13/16"	BSH10319	3 3/16"	BSH15231	2 5/16"	BSH15400	4"	BSH25338	3 3/8"	BSH25575	5 ¾"
BSH75188	1 7/8"	BSH10188	1 7/8"	BSH10325	3 ¼"	BSH15238	2 3/8"	BSH15105	4 1/8"	BSH25350	3 1/2"	BSH25150	5 7/8"
BSH75194	1 15/16"	BSH10194	1 15/16"	BSH10338	3 3/8"	BSH15244	2 7/16"	BSH15419	4 3/16"	BSH25363	3 5/8"	BSH25600	6"
BSH75200	2"	BSH10200	2"	BSH10350	3 1/2"	BSH15250	2 1/2"	BSH15425	4 ¼"	BSH2595	3 ¾"	BSH25613	6 1/8"
-	-	BSH10206	2 1/16"	BSH10363	3 5/8"	BSH1565	2 9/16"	BSH15110	4 5/16"	BSH25388	3 7/8"	-	-
-	-	BSH10213	2 1/8"	BSH1095	3 ¾"	BSH15263	2 5/8"	BSH15438	4 3/8"	BSH25100	3 15/16"	-	-
-	-	BSH10219	2 3/16"	BSH10388	3 7/8"	BSH15269	2 11/16"	BSH15450	4 1/2"	BSH25400	4"	-	-
-	-	BSH10225	2 ¼"	-	-	BSH1570	2 ¾"	BSH15463	4 5/8"	BSH25105	4 1/8"	-	-

Enerpac professional series steel torque wrenches provide reliable controlled tightening solutions across the industry.

### ***S3000X Square Drive Torque Wrench on wind tower erection and maintenance***

*S3000X used to connect wind tower segments during assembly and maintenance. A robust but compact solution is required for tightening of bolts on wind tower sections. Large numbers of fasteners require precise application of torque to ensure joint integrity is achieved and maintained. The Enerpac S-Series wrench was selected as it offers simple and reliable operation while providing accurate and repeatable results.*



### ***W4000X Low Profile Torque Wrench on an API Pipe Flange***

*Throughout the Oil and Gas, Petrochemical and Processing Industries, pipeline joints, valves, pumps and machinery present challenges for controlled bolting. The restricted access on this flange was easily overcome with an Enerpac W-Series Torque Wrench. These wrenches offer reliability and control, ensuring even and consistent torque is applied to all bolts.*

### ***S3000X on an oil and gas flange***

*During maintenance quick turnaround times are essential; S-Series wrenches are chosen as they provide a large angle of nut rotation per stroke, offering speed and accuracy in a compact ergonomic tool.*



▼ Shown: W4206X hexagon cassette with W4000X drive unit (rear model shows optional straight handle)



## Setting New Standards in Safety, Simplicity and Performance

### Safety and Performance

- Superior strength to size ratio provides easy access to difficult to reach applications without sacrificing endurance
- 30° rotation angle and rapid return stroke provide fast operation
- Tough manifold design with added safety feature for enhanced operator safety

### Simplicity

- Fast release drive unit enables rapid exchange of cassettes, no tools required
- Quick and easy disassembly for maintenance without special tools
- Include robust handle which mounts on both sides and the tops of cassettes to allow for extra maneuverability

### Versatility

- Available with optional enhanced tilt and swivel TSP300 manifold for horizontal and vertical maneuverability, with greater durability <sup>1)</sup>
- X-Edition drive units, cassettes and most accessories are compatible with standard edition tools <sup>1)</sup>
- Drive unit compatible with UltraSlim and WCR-Series cassettes

### Accuracy

- Constant torque output provides accuracy of  $\pm 3\%$  across full stroke.



#### Two Handle Styles

Robust angled positioning handle comes standard with every W-Series (X-Edition) cassette.

Straight positioning handles designed for extreme limited access applications are available as accessories.

Compatible with W-Series (X-Edition) Cassettes	Model Nr. Angled positioning handles (standard)	Model Nr. Straight positioning handles (optional)
W2000X, W4000X	<b>SWH6A</b>	<b>SWH6S</b>
W8000X, W15000X	<b>SWH10A</b>	<b>SWH10S</b>
W22000X, W35000X	<b>SWH10EA</b> <sup>2)</sup>	

<sup>2)</sup> SWH10EA is an eyebolt handle.



#### TSP - Pro Series Swivel

The optional TSP300 tilt and swivel manifold with robust interlocking design provides 360° X-axis rotation and 160° Y-axis rotation.

#### How to Order <sup>1)</sup>

Factory fitted to W-Series (X-Edition) drive units: Insert a "P" prior to the "X" in the tool model number, example: **W2000PX**.

Order as an accessory using the model number: **TSP300**, which can be fitted to existing W-Series (X-Edition) drive units. Includes male and female couplers.

Page: 25



#### ATEX declared. Calibration certificate included.

All X-edition tools are CE - ATEX declared and are shipped complete with a calibration certificate.



<sup>1)</sup> TSP300 is designed for X-Edition tools only, and is not compatible with standard edition tools. For replacement components for existing tools, refer to repair sheet on [www.enerpac.com](http://www.enerpac.com)

# Double-Acting Hydraulic Hexagon Torque Wrenches

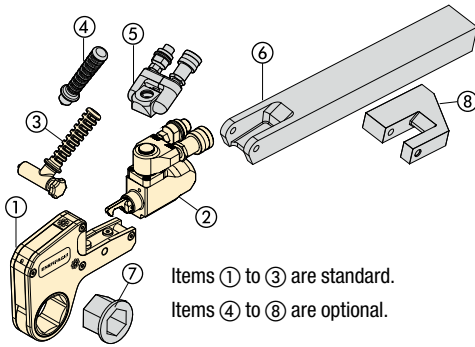

- ① Hexagon Cassette (pages 14-21)
- ② Drive Unit (page 13)
- ③ Angled Positioning Handle (page 12)
- ④ Straight Positioning Handle (page 12)
- ⑤ Pro Series Swivel (page 25)
- ⑥ Extended Reaction Arm (page 25)
- ⑦ Reducer Insert (pages 14-21)
- ⑧ Reaction Paddle (page 25)

Items ① to ③ are standard.  
Items ④ to ⑧ are optional.

## W Series X-Edition



Maximum Torque at 690 bar:  
**47.454 Nm**

Hexagon Range:  
**30 - 155 mm, 1 1/16 - 6 1/8"**

Nose Radius:  
**31 - 115 mm**

Maximum Operating Pressure:  
**690 bar**

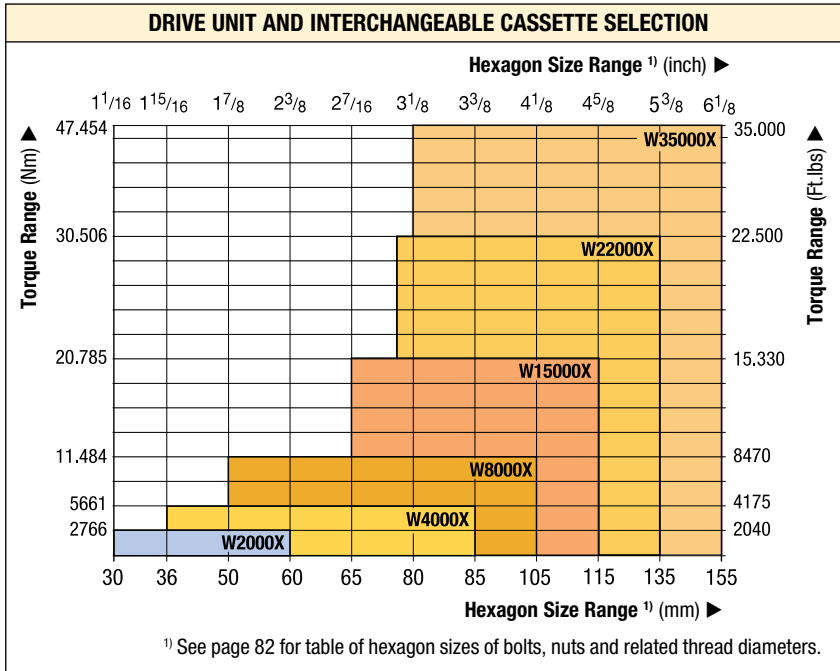

### Torque Wrench Pump Selection Matrix

For optimum speed and performance see the torque wrench and pump matrix.

Page: **40**

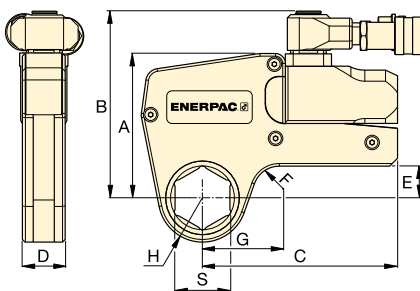

*These rigid steel wrenches with low profile interchangeable hexagon cassettes guarantee durability and maximum versatility in bolting applications. ▶*



### ▼ SELECTION CHART

Hexagon Range *		Maximum Torque at 690 bar		Drive Unit Model Number **	Minimum Torque		Dimensions (mm) (see pages 14-21 for dimensions H, G and S)						Weight (drive unit without hexagon cassette) (kg)
(mm)	(inch)	(Nm)	(Ft.lbs)		(Nm)	(Ft.lbs)	A	B	C	D	E	F	
30 - 60	1 1/16 - 2 3/8	2766	2040	<b>W2000X</b>	276	204	109	141	148	32	24	20	1,4
36 - 85	1 5/16 - 3 3/8	5661	4175	<b>W4000X</b>	566	417	136	167	178	41	33	20	2,0
50 - 105	1 7/8 - 4 1/8	11.484	8470	<b>W8000X</b>	1148	847	172	205	208	53	42	25	3,0
65 - 115	2 7/16 - 4 5/8	20.785	15.330	<b>W15000X</b>	2078	1533	207	240	253	63	50	20	5,0
75 - 135	2 15/16 - 5 3/8	30.506	22.500	<b>W22000X</b>	3050	2250	227	266	297	77	48	35	7,7
80 - 155	3 1/8 - 6 1/8	47.454	35.000	<b>W35000X</b>	4745	3500	268	301	345	91	69-73	50	11,4

\* With in-line reaction foot.

\*\* To order a wrench fitted with the TSP swivel, suffix the model number with "P". Example: **W2000PX**. See page 85 for torque conversions and tables of pressure versus torque.

# W2000X, Inch-Cassettes & Reducer Inserts

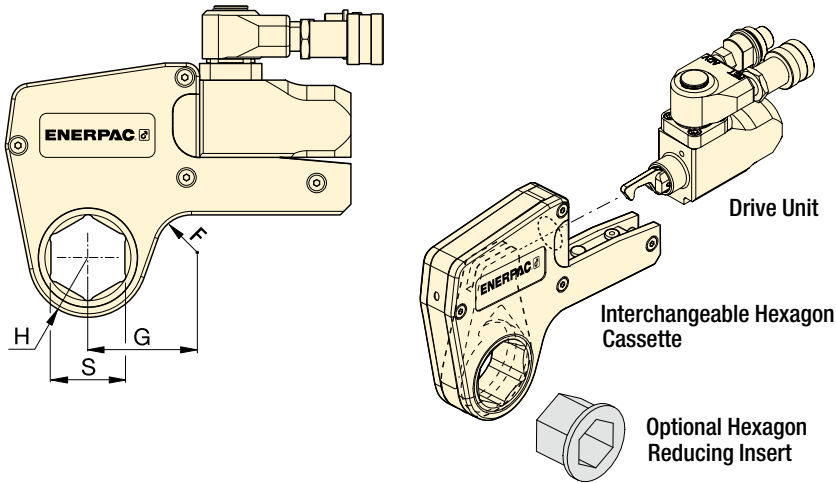

## W Series X-Edition



Maximum Torque at 690 bar:  
**2766 Nm**

Hexagon Range:  
**1 1/8 - 2 3/8 inch**

Maximum Operating Pressure:  
**690 bar**



### Metric Sizes

For metric sizes of hexagon cassettes and reducer inserts see:

Page: **20**



### Hexagon Bolt and Nut Sizes

See the table for hexagon sizes of bolts, nuts and related thread diameters.

Page: **82**

### ▼ SELECTION CHART

Drive Unit Model Number	Hexagon Size S (inch)	Nose Radius H (mm)	G (mm)	Model Nr. Cassette	Weight (kg)	Hexagon Reducer (inch)		Hexagon Reducer (inch)		Hexagon Reducer (inch)	
						Model Number Reducer	Model Number Reducer	Model Number Reducer	Model Number Reducer		
<b>W2000X</b>	1 1/16	31,0	53,7	<b>W2101X</b>	2,1	-	-	-	-	-	-
	1 1/8	31,0	53,7	<b>W2102X</b>	2,1	-	-	-	-	-	-
	1 3/16	31,0	53,7	<b>W2103X</b>	2,1	-	-	-	-	-	-
	1 1/4	31,0	53,7	<b>W2104X</b>	2,1	-	-	-	-	-	-
	1 5/16	31,0	53,7	<b>W2105X</b>	2,1	-	-	-	-	-	-
	1 3/8	31,0	53,7	<b>W2106X</b>	2,1	-	-	-	-	-	-
	1 7/16	31,0	53,7	<b>W2107X</b>	2,1	1 7/16 - 1 1/8	<b>W2107R102</b>	-	-	-	-
	1 1/2	33,5	58,2	<b>W2108X</b>	2,2	-	-	-	-	-	-
	1 9/16	33,5	58,2	<b>W2109X</b>	2,2	-	-	-	-	-	-
	1 5/8	33,5	58,2	<b>W2110X</b>	2,2	1 5/8 - 1 1/4	<b>W2110R104</b>	1 5/8 - 1 3/16	<b>W2110R103</b>	-	-
	1 11/16	36,5	60,5	<b>W2111X</b>	2,2	-	-	-	-	-	-
	1 3/4	36,5	60,5	<b>W2112X</b>	2,2	-	-	-	-	-	-
	1 13/16	36,5	60,5	<b>W2113X</b>	2,2	1 13/16 - 1 7/16	<b>W2113R107</b>	1 13/16 - 1 1/4	<b>W2113R104</b>	-	-
	1 7/8	39,0	63,1	<b>W2114X</b>	2,2	-	-	-	-	-	-
	1 15/16	39,0	63,1	<b>W2115X</b>	2,2	-	-	-	-	-	-
	2	39,0	63,1	<b>W2200X</b>	2,2	2 - 1 5/8	<b>W2200R110</b>	2 - 1 7/16	<b>W2200R107</b>	-	-
	2 1/16	41,8	68,6	<b>W2201X</b>	2,3	-	-	-	-	-	-
	2 1/8	41,8	68,6	<b>W2202X</b>	2,3	-	-	-	-	-	-
	2 3/16	41,8	68,6	<b>W2203X</b>	2,3	2 3/16 - 1 13/16	<b>W2203R113</b>	2 3/16 - 1 5/8	<b>W2203R110</b>	2 3/16 - 1 7/16	<b>W2203R107</b>
	-	-	-	-	-	-	-	-	-	-	-
2 1/4	44,5	64,8	<b>W2204X</b>	2,2	-	-	-	-	-	-	
2 5/16	44,5	64,8	<b>W2205X</b>	2,2	-	-	-	-	-	-	
2 3/8	44,5	64,8	<b>W2206X</b>	2,2	2 3/8 - 2	<b>W2206R200</b>	2 3/8 - 1 7/8	<b>W2206R114</b>	2 3/8 - 1 13/16	<b>W2206R113</b>	
-	-	-	-	-	-	2 3/8 - 1 1/2	<b>W2206R108</b>	2 3/8 - 1 7/16	<b>W2206R107</b>	2 3/8 - 1 5/16	<b>W2206R110</b>



# W4000X, Inch-Cassettes & Reducer Inserts

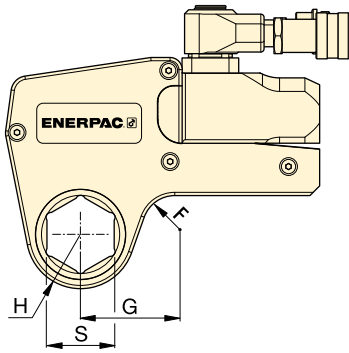

Maximum Torque at 690 bar:

**5661 Nm**

Hexagon Range:

**1<sup>5</sup>/<sub>16</sub> - 3<sup>3</sup>/<sub>8</sub> inch**

Maximum Operating Pressure:

**690 bar**

**W**

**Series  
X-Edition**



▼ **SELECTION CHART**

Drive Unit Model Number	Hexagon Size <sup>1)</sup> S (inch)	Nose Radius H (mm)	G (mm)	Model Nr. Cassette	Weight (kg)	Hexagon Reducer		Model Number Reducer		Hexagon Reducer		Model Number Reducer		
						(inch)	Model Number Reducer	(inch)	Model Number Reducer	(inch)	Model Number Reducer			
W4000X	1 <sup>5</sup> / <sub>16</sub>	37,0	61,0	W4105X	3,7	-	-	-	-	-	-	-	-	
	1 <sup>3</sup> / <sub>8</sub>	37,0	61,0	W4106X	3,7	-	-	-	-	-	-	-	-	
	1 <sup>7</sup> / <sub>16</sub>	37,0	61,0	W4107X	3,7	-	-	-	-	-	-	-	-	
	1 <sup>1</sup> / <sub>2</sub>	37,0	61,0	W4108X	3,7	-	-	-	-	-	-	-	-	
	1 <sup>9</sup> / <sub>16</sub>	37,0	61,0	W4109X	3,7	-	-	-	-	-	-	-	-	
	1 <sup>5</sup> / <sub>8</sub>	37,0	61,0	W4110X	3,7	-	-	-	-	-	-	-	-	
	1 <sup>11</sup> / <sub>16</sub>	39,5	64,0	W4111X	3,8	-	-	-	-	-	-	-	-	
	1 <sup>3</sup> / <sub>4</sub>	39,5	64,0	W4112X	3,8	-	-	-	-	-	-	-	-	
	1 <sup>13</sup> / <sub>16</sub>	39,5	64,0	W4113X	3,8	-	-	-	-	-	-	-	-	
	1 <sup>7</sup> / <sub>8</sub>	41,5	66,7	W4114X	3,9	-	-	-	-	-	-	-	-	
	1 <sup>15</sup> / <sub>16</sub>	41,5	66,7	W4115X	3,9	-	-	-	-	-	-	-	-	
	2	41,5	66,7	W4200X	3,9	2 - 1 <sup>7</sup> / <sub>16</sub>	W4200R107	-	-	-	-	-	-	-
	2 <sup>1</sup> / <sub>16</sub>	44,0	73,4	W4201X	4	-	-	-	-	-	-	-	-	-
	2 <sup>1</sup> / <sub>8</sub>	44,0	73,4	W4202X	4	-	-	-	-	-	-	-	-	-
	2 <sup>3</sup> / <sub>16</sub>	44,0	73,4	W4203X	4	2 <sup>3</sup> / <sub>16</sub> - 1 <sup>5</sup> / <sub>8</sub>	W4203R110	2 <sup>3</sup> / <sub>16</sub> - 1 <sup>7</sup> / <sub>16</sub>	W4203R107	2 <sup>3</sup> / <sub>16</sub> - 1 <sup>1</sup> / <sub>4</sub>	W4203R104	-	-	-
	2 <sup>1</sup> / <sub>4</sub>	46,5	70,6	W4204X	4,1	-	-	-	-	-	-	-	-	-
	2 <sup>5</sup> / <sub>16</sub>	46,5	70,6	W4205X	4,1	-	-	-	-	-	-	-	-	-
	2 <sup>3</sup> / <sub>8</sub>	46,5	70,6	W4206X	4,1	2 <sup>3</sup> / <sub>8</sub> - 2	W4206R200	2 <sup>3</sup> / <sub>8</sub> - 1 <sup>13</sup> / <sub>16</sub>	W4206R113	2 <sup>3</sup> / <sub>8</sub> - 1 <sup>7</sup> / <sub>16</sub>	W4206R107	-	-	-
	-	-	-	-	-	2 <sup>3</sup> / <sub>8</sub> - 1 <sup>3</sup> / <sub>8</sub>	W4206R106	-	-	-	-	-	-	-
	2 <sup>7</sup> / <sub>16</sub>	49,5	76,2	W4207X	4,1	2 <sup>7</sup> / <sub>16</sub> - 2	W4207R200	-	-	-	-	-	-	-
	2 <sup>1</sup> / <sub>2</sub>	49,5	76,2	W4208X	4,1	2 <sup>1</sup> / <sub>2</sub> - 2	W4208R200	2 <sup>1</sup> / <sub>2</sub> - 1 <sup>13</sup> / <sub>16</sub>	W4208R113	2 <sup>1</sup> / <sub>2</sub> - 2 <sup>1</sup> / <sub>16</sub>	W4208R201	-	-	-
	2 <sup>9</sup> / <sub>16</sub>	49,5	76,2	W4209X	4,1	2 <sup>9</sup> / <sub>16</sub> - 2 <sup>3</sup> / <sub>16</sub>	W4209R203	2 <sup>9</sup> / <sub>16</sub> - 2 <sup>1</sup> / <sub>8</sub>	W4209R202	2 <sup>9</sup> / <sub>16</sub> - 2 <sup>1</sup> / <sub>16</sub>	W4209R201	-	-	-
	-	-	-	-	-	2 <sup>9</sup> / <sub>16</sub> - 2	W4209R200	2 <sup>9</sup> / <sub>16</sub> - 1 <sup>13</sup> / <sub>16</sub>	W4209R113	-	-	-	-	-
	2 <sup>5</sup> / <sub>8</sub>	52,5	78,3	W4210X	4,2	-	-	-	-	-	-	-	-	-
	2 <sup>11</sup> / <sub>16</sub>	52,5	78,3	W4211X	4,2	-	-	-	-	-	-	-	-	-
	2 <sup>3</sup> / <sub>4</sub>	52,5	78,3	W4212X	4,2	2 <sup>3</sup> / <sub>4</sub> - 2 <sup>3</sup> / <sub>8</sub>	W4212R206	2 <sup>3</sup> / <sub>4</sub> - 2 <sup>3</sup> / <sub>16</sub>	W4212R203	2 <sup>3</sup> / <sub>4</sub> - 2 <sup>1</sup> / <sub>8</sub>	W4212R202	-	-	-
	2 <sup>13</sup> / <sub>16</sub>	55,3	81,6	W4213X	4,3	-	-	-	-	-	-	-	-	-
	2 <sup>7</sup> / <sub>8</sub>	55,3	81,6	W4214X	4,3	-	-	-	-	-	-	-	-	-
	2 <sup>15</sup> / <sub>16</sub>	55,3	81,6	W4215X	4,3	2 <sup>15</sup> / <sub>16</sub> - 2 <sup>9</sup> / <sub>16</sub>	W4215R209	2 <sup>15</sup> / <sub>16</sub> - 2 <sup>3</sup> / <sub>8</sub>	W4215R206	2 <sup>15</sup> / <sub>16</sub> - 2 <sup>3</sup> / <sub>16</sub>	W4215R203	-	-	-
	-	-	-	-	-	2 <sup>15</sup> / <sub>16</sub> - 2	W4215R200	-	-	-	-	-	-	-
	3	58,5	83,5	W4300X	4,4	3 - 2 <sup>3</sup> / <sub>16</sub>	W4300R203	-	-	-	-	-	-	-
	3 <sup>1</sup> / <sub>16</sub>	58,5	83,5	W4301X	4,4	-	-	-	-	-	-	-	-	-
3 <sup>1</sup> / <sub>8</sub>	58,5	83,5	W4302X	4,4	3 <sup>1</sup> / <sub>8</sub> - 2 <sup>3</sup> / <sub>4</sub>	W4302R212	3 <sup>1</sup> / <sub>8</sub> - 2 <sup>9</sup> / <sub>16</sub>	W4302R209	3 <sup>1</sup> / <sub>8</sub> - 2 <sup>3</sup> / <sub>8</sub>	W4302R206	-	-	-	
-	-	-	-	-	3 <sup>1</sup> / <sub>8</sub> - 2 <sup>9</sup> / <sub>16</sub>	W4302R205	3 <sup>1</sup> / <sub>8</sub> - 2 <sup>1</sup> / <sub>4</sub>	W4302R204	3 <sup>1</sup> / <sub>8</sub> - 2 <sup>3</sup> / <sub>16</sub>	W4302R203	-	-	-	
-	-	-	-	-	3 <sup>1</sup> / <sub>8</sub> - 2 <sup>3</sup> / <sub>16</sub>	W4302R203	3 <sup>1</sup> / <sub>8</sub> - 2 <sup>1</sup> / <sub>8</sub>	W4302R202	3 <sup>1</sup> / <sub>8</sub> - 2	W4302R200	-	-	-	
3 <sup>3</sup> / <sub>16</sub>	62,0	85,5	W4303X	4,5	-	-	-	-	-	-	-	-	-	
3 <sup>1</sup> / <sub>4</sub>	62,0	85,5	W4304X	4,5	-	-	-	-	-	-	-	-	-	
3 <sup>5</sup> / <sub>16</sub>	62,0	85,5	W4305X	4,5	-	-	-	-	-	-	-	-	-	
3 <sup>3</sup> / <sub>8</sub>	62,0	85,5	W4306X	4,5	-	-	-	-	-	-	-	-	-	

<sup>1)</sup> See page 82 for table of hexagon sizes of bolts, nuts and related thread diameters.

# W8000X, Inch-Cassettes & Reducer Inserts

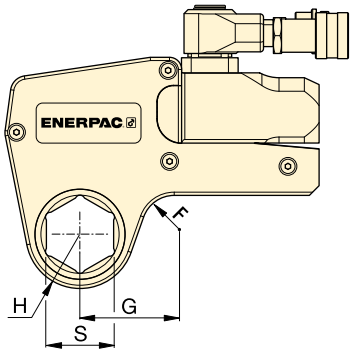

Maximum Torque at 690 bar:

**11.484 Nm**

Hexagon Range:

**1 7/8 - 4 1/8 inch**

Maximum Operating Pressure:

**690 bar**

**W**  
Series  
X-Edition



▼ **SELECTION CHART**

Drive Unit Model Number	Hexagon Size <sup>1)</sup> S (inch)	Nose Radius H (mm)	G (mm)	Model Number Cassette	Weight (kg)	Hexagon Reducer		Hexagon Reducer		Hexagon Reducer	
						Model Number Reducer	Hexagon Reducer (inch)	Model Number Reducer	Hexagon Reducer (inch)	Model Number Reducer	Hexagon Reducer (inch)
W8000X	1 7/8	45,0	78,2	W8114X	8,1	-	-	-	-	-	-
	1 15/16	45,0	78,2	W8115X	8,1	-	-	-	-	-	-
	2	45,0	78,2	W8200X	8,1	-	-	-	-	-	-
	2 1/16	48,0	80,0	W8201X	8,1	-	-	-	-	-	-
	2 1/8	48,0	80,0	W8202X	8,1	-	-	-	-	-	-
	2 3/16	48,0	80,0	W8203X	8,1	-	-	-	-	-	-
	2 1/4	51,0	82,5	W8204X	8,1	-	-	-	-	-	-
	2 5/16	51,0	82,5	W8205X	8,1	-	-	-	-	-	-
	2 3/8	51,0	82,5	W8206X	8,1	-	-	-	-	-	-
	2 7/16	52,5	85,9	W8207X	8,1	-	-	-	-	-	-
	2 1/2	52,5	85,9	W8208X	8,1	-	-	-	-	-	-
	2 9/16	52,5	85,9	W8209X	8,1	2 9/16 - 2	W8209R200	-	-	-	-
	2 5/8	56,0	84,8	W8210X	8,1	-	-	-	-	-	-
	2 11/16	56,0	84,8	W8211X	7,9	-	-	-	-	-	-
	2 3/4	56,0	84,8	W8212X	7,9	2 3/4 - 2 3/16	W8212R203	-	-	-	-
	2 13/16	58,0	85,0	W8213X	7,9	-	-	-	-	-	-
	2 7/8	58,0	85,0	W8214X	7,9	-	-	-	-	-	-
	2 15/16	58,0	85,0	W8215X	7,9	2 15/16 - 2 3/8	W8215R206	2 15/16 - 2 3/16	W8215R203	-	-
	3	60,5	89,5	W8300X	8,0	-	-	-	-	-	-
	3 1/16	60,5	89,5	W8301X	8,0	-	-	-	-	-	-
	3 1/8	60,5	89,5	W8302X	8,0	3 1/8 - 2 9/16	W8302R209	3 1/8 - 2 3/8	W8302R206	3 1/8 - 2 3/16	W8302R203
	-	-	-	-	-	3 1/8 - 2	W8302R200	-	-	-	-
	3 3/16	66,0	92,2	W8303X	8,2	-	-	-	-	-	-
	3 1/4	66,0	92,2	W8304X	8,2	-	-	-	-	-	-
	3 5/16	66,0	92,2	W8305X	8,2	-	-	-	-	-	-
	3 3/8	66,0	92,2	W8306X	8,2	-	-	-	-	-	-
	3 7/16	66,0	92,2	W8307IX	8,2	-	-	-	-	-	-
	3 1/2	66,0	92,2	W8308X	8,2	3 1/2 - 3	W8308R300	3 1/2 - 2 15/16	W8308R215	3 1/2 - 2 3/4	W8308R212
	3 9/16	74,0	102,9	W8309X	8,8	-	-	-	-	-	-
	3 5/8	74,0	102,9	W8310X	8,8	-	-	-	-	-	-
	3 11/16	74,0	102,9	W8311X	8,8	-	-	-	-	-	-
	3 3/4	74,0	102,9	W8312X	8,8	3 3/4 - 3 1/8	W8312R302	3 3/4 - 2 15/16	W8312R215	3 3/4 - 2 3/4	W8312R212
3 13/16	74,0	102,9	W8313X	8,8	-	-	-	-	-	-	
3 7/8	74,0	102,9	W8314X	8,8	3 7/8 - 3 1/8	W8314R302	3 7/8 - 2 15/16	W8314R215	-	-	
3 15/16	79,5	110,0	W8315X	9,3	-	-	-	-	-	-	
4	79,5	110,0	W8400X	9,3	-	-	-	-	-	-	
4 1/16	79,5	110,0	W8401IX	9,3	-	-	-	-	-	-	
4 1/8	79,5	110,0	W8402X	9,3	-	-	-	-	-	-	

<sup>1)</sup> See page 82 for table of hexagon sizes of bolts, nuts and related thread diameters.

# W15000X, Inch-Cassettes & Reducer Inserts

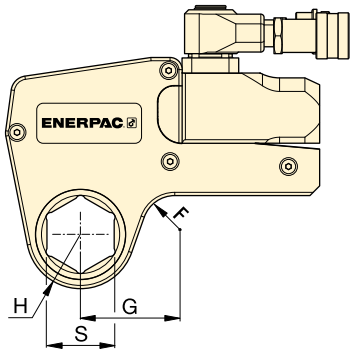

Maximum Torque at 690 bar:

**20.785 Nm**

Hexagon Range:

**2 1/8 - 4 5/8 inch**

Maximum Operating Pressure:

**690 bar**

**W**  
Series  
X-Edition



## ▼ SELECTION CHART

Drive Unit Model Number	Hexagon Size <sup>1)</sup> S	Nose Radius H	G	Model Nr. Cassette	Weight (kg)	Hexagon Reducer		Hexagon Reducer		Hexagon Reducer	
						Hexagon Reducer (inch)	Model Number Reducer	Hexagon Reducer (inch)	Model Number Reducer	Hexagon Reducer (inch)	Model Number Reducer
W15000X	2 7/16	59,0	88,6	W15207X	13,6	-	-	-	-	-	-
	2 1/2	59,0	88,6	W15208X	13,6	-	-	-	-	-	-
	2 9/16	59,0	88,6	W15209X	13,6	-	-	-	-	-	-
	2 5/8	59,0	88,6	W15210X	13,6	-	-	-	-	-	-
	2 11/16	59,0	88,6	W15211X	13,6	-	-	-	-	-	-
	2 3/4	59,0	88,6	W15212X	13,6	-	-	-	-	-	-
	2 13/16	62,0	90,5	W15213X	13,7	-	-	-	-	-	-
	2 7/8	62,0	90,5	W15214X	13,7	-	-	-	-	-	-
	2 15/16	62,0	90,5	W15215X	13,7	-	-	-	-	-	-
	3	64,5	92,9	W15300X	13,8	3 - 2 1/8	W15300R202	-	-	-	-
	3 1/16	64,5	92,9	W15301X	13,8	-	-	-	-	-	-
	3 1/8	64,5	92,9	W15302X	13,8	3 1/8 - 2 9/16	W15302R209	-	-	-	-
	3 3/16	69,5	96,6	W15303X	14,1	-	-	-	-	-	-
	3 1/4	69,5	96,6	W15304X	14,1	-	-	-	-	-	-
	3 5/16	69,5	96,6	W15305X	14,1	-	-	-	-	-	-
	3 3/8	69,5	96,6	W15306X	14,1	-	-	-	-	-	-
	3 7/16	69,5	96,6	W15307IX	14,1	-	-	-	-	-	-
	3 1/2	69,5	96,6	W15308X	14,1	3 1/2 - 2 15/16	W15308R215	3 1/2 - 2 3/4	W15308R212	-	-
	3 9/16	75,0	101,8	W15309X	14,6	-	-	-	-	-	-
	3 5/8	75,0	101,8	W15310X	14,6	-	-	-	-	-	-
	3 11/16	75,0	101,8	W15311X	14,6	-	-	-	-	-	-
	3 3/4	75,0	101,8	W15312X	14,6	3 3/4 - 3 1/8	W15312R302	3 3/4 - 2 15/16	W15312R215	-	-
	3 13/16	75,0	101,8	W15313X	14,5	-	-	-	-	-	-
	3 7/8	75,0	101,8	W15314X	14,5	3 7/8 - 3 1/8	W15314R302	3 7/8 - 2 15/16	W15314R215	-	-
	3 15/16	80,5	103,1	W15315X	14,8	-	-	-	-	-	-
	4	80,5	103,1	W15400X	14,8	-	-	-	-	-	-
	4 1/16	80,5	103,1	W15401IX	14,8	-	-	-	-	-	-
	4 1/8	80,5	103,1	W15402X	14,8	4 1/8 - 3 1/2	W15402R308	4 1/8 - 3 5/16	W15402R305	4 1/8 - 3 1/4	W15402R304
	4 3/16	80,5	103,1	W15403IX	14,8	-	-	-	-	-	-
	4 1/4	80,5	103,1	W15404X	14,8	4 1/4 - 3 1/2	W15404R308	4 1/4 - 3 1/8	W15404R302	-	-
	4 5/16	87,5	114,8	W15405X	15,1	-	-	-	-	-	-
	4 3/8	87,5	114,8	W15406X	15,1	-	-	-	-	-	-
4 7/16	87,5	114,8	W15407X	15,1	-	-	-	-	-	-	
4 1/2	87,5	114,8	W15408IX	15,1	-	-	-	-	-	-	
4 9/16	87,5	114,8	W15409IX	15,1	-	-	-	-	-	-	
4 5/8	87,5	114,8	W15410IX	15,1	4 5/8 - 3 15/16	W15410R315	4 5/8 - 3 7/8	W15410R314	4 5/8 - 3 3/4	W15410R312	
-	-	-	-	-	-	4 5/8 - 3 1/2	W15410R308	-	-	-	

<sup>1)</sup> See page 82 for table of hexagon sizes of bolts, nuts and related thread diameters.

# W22000X, Inch-Cassettes & Reducers

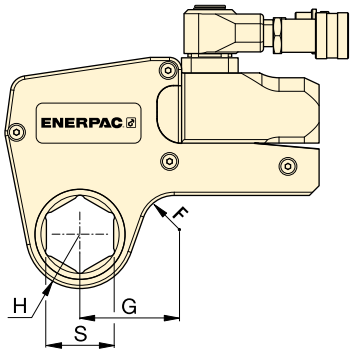

Maximum Torque at 690 bar:

**30.506 Nm**

Hexagon Range:

**2<sup>15</sup>/<sub>16</sub> - 5<sup>3</sup>/<sub>8</sub> inch**

Maximum Operating Pressure:

**690 bar**

**W**  
Series  
X-Edition



▼ **SELECTION CHART**

Drive Unit Model Number	Hexagon Size <sup>1)</sup> S (inch)	Nose Radius H (mm)	G (mm)	Model Nr. Cassette	Weight (kg)	Hexagon Reducer		Model Number Reducer		Hexagon Reducer		Model Number Reducer	
						Hexagon Reducer (inch)	Model Number Reducer	Hexagon Reducer (inch)	Model Number Reducer	Hexagon Reducer (inch)	Model Number Reducer		
W22000X	2 <sup>15</sup> / <sub>16</sub>	67,0	102,1	W22215X	22,1	-	-	-	-	-	-	-	-
	3	67,0	102,1	W22300X	22,0	-	-	-	-	-	-	-	-
	3 <sup>1</sup> / <sub>16</sub>	67,0	102,1	W22301X	21,9	-	-	-	-	-	-	-	-
	3 <sup>1</sup> / <sub>8</sub>	67,0	102,1	W22302X	21,6	3 <sup>1</sup> / <sub>8</sub> - 2 <sup>3</sup> / <sub>8</sub>	W22302R206	3 <sup>1</sup> / <sub>8</sub> - 2 <sup>3</sup> / <sub>16</sub>	W22302R203	-	-	-	-
	3 <sup>3</sup> / <sub>16</sub>	72,4	107,4	W22303X	22,9	-	-	-	-	-	-	-	-
	3 <sup>1</sup> / <sub>4</sub>	72,4	107,4	W22304X	22,8	-	-	-	-	-	-	-	-
	3 <sup>5</sup> / <sub>16</sub>	72,4	107,4	W22305X	22,6	-	-	-	-	-	-	-	-
	3 <sup>3</sup> / <sub>8</sub>	72,4	107,4	W22306X	22,5	-	-	-	-	-	-	-	-
	3 <sup>7</sup> / <sub>16</sub>	72,4	107,4	W22307IX	22,8	-	-	-	-	-	-	-	-
	3 <sup>1</sup> / <sub>2</sub>	72,4	107,4	W22308X	22,2	3 <sup>1</sup> / <sub>2</sub> - 2 <sup>3</sup> / <sub>4</sub>	W22308R212	3 <sup>1</sup> / <sub>2</sub> - 2 <sup>9</sup> / <sub>16</sub>	W22308R209	3 <sup>1</sup> / <sub>2</sub> - 2 <sup>3</sup> / <sub>8</sub>	W22308R206	-	-
	3 <sup>9</sup> / <sub>16</sub>	77,9	113,0	W22309X	23,4	-	-	-	-	-	-	-	-
	3 <sup>5</sup> / <sub>8</sub>	77,9	113,0	W22310X	23,3	-	-	-	-	-	-	-	-
	3 <sup>11</sup> / <sub>16</sub>	77,9	113,0	W22311X	23,1	-	-	-	-	-	-	-	-
	3 <sup>3</sup> / <sub>4</sub>	77,9	113,0	W22312X	22,9	3 <sup>3</sup> / <sub>4</sub> - 2 <sup>15</sup> / <sub>16</sub>	W22312R215	-	-	-	-	-	-
	3 <sup>13</sup> / <sub>16</sub>	77,9	113,0	W22313X	22,8	-	-	-	-	-	-	-	-
	3 <sup>7</sup> / <sub>8</sub>	77,9	113,0	W22314X	22,6	3 <sup>7</sup> / <sub>8</sub> - 3 <sup>1</sup> / <sub>8</sub>	W22314R302	3 <sup>7</sup> / <sub>8</sub> - 2 <sup>15</sup> / <sub>16</sub>	W22314R215	3 <sup>7</sup> / <sub>8</sub> - 2 <sup>3</sup> / <sub>4</sub>	W22314R212	-	-
	3 <sup>15</sup> / <sub>16</sub>	85,1	119,9	W22315X	24,3	-	-	-	-	-	-	-	-
	4	85,1	119,9	W22400X	24,1	-	-	-	-	-	-	-	-
	4 <sup>1</sup> / <sub>16</sub>	85,1	119,9	W22401IX	24,0	-	-	-	-	-	-	-	-
	4 <sup>1</sup> / <sub>8</sub>	85,1	119,9	W22402X	23,6	-	-	-	-	-	-	-	-
	4 <sup>3</sup> / <sub>16</sub>	85,1	119,9	W22403IX	23,6	-	-	-	-	-	-	-	-
	4 <sup>1</sup> / <sub>4</sub>	85,1	119,9	W22404X	24,6	4 <sup>1</sup> / <sub>4</sub> - 3 <sup>1</sup> / <sub>2</sub>	W22404R308	4 <sup>1</sup> / <sub>4</sub> - 3 <sup>1</sup> / <sub>8</sub>	W22404R302	4 <sup>1</sup> / <sub>4</sub> - 2 <sup>15</sup> / <sub>16</sub>	W22404R215	-	-
	4 <sup>5</sup> / <sub>16</sub>	89,9	125,0	W22405X	24,6	-	-	-	-	-	-	-	-
	4 <sup>3</sup> / <sub>8</sub>	89,9	125,0	W22406X	24,5	-	-	-	-	-	-	-	-
	4 <sup>7</sup> / <sub>16</sub>	89,9	125,0	W22407X	24,3	-	-	-	-	-	-	-	-
	4 <sup>1</sup> / <sub>2</sub>	89,9	125,0	W22408X	24,1	-	-	-	-	-	-	-	-
	4 <sup>9</sup> / <sub>16</sub>	89,9	125,0	W22409IX	23,9	-	-	-	-	-	-	-	-
	4 <sup>5</sup> / <sub>8</sub>	89,9	125,0	W22410IX	23,6	4 <sup>5</sup> / <sub>8</sub> - 3 <sup>7</sup> / <sub>8</sub>	W22410R314	4 <sup>5</sup> / <sub>8</sub> - 3 <sup>3</sup> / <sub>4</sub>	W22410R312	4 <sup>5</sup> / <sub>8</sub> - 3 <sup>1</sup> / <sub>2</sub>	W22410R308	-	-
	4 <sup>3</sup> / <sub>4</sub>	95,0	130,0	W22412X	24,7	-	-	-	-	-	-	-	-
	4 <sup>7</sup> / <sub>8</sub>	95,0	130,0	W22414X	24,3	-	-	-	-	-	-	-	-
	5	95,0	130,0	W22500X	23,8	5 - 4 <sup>1</sup> / <sub>4</sub>	W22500R404	5 - 4 <sup>1</sup> / <sub>8</sub>	W22500R402	5 - 3 <sup>7</sup> / <sub>8</sub>	W22500R314	-	-
	5 <sup>1</sup> / <sub>8</sub>	100,0	134,8	W22502X	25,0	-	-	-	-	-	-	-	-
5 <sup>3</sup> / <sub>16</sub>	100,0	134,8	W22503X	24,8	-	-	-	-	-	-	-	-	
5 <sup>1</sup> / <sub>4</sub>	100,0	134,8	W22504X	24,5	-	-	-	-	-	-	-	-	
5 <sup>3</sup> / <sub>8</sub>	100,0	134,8	W22506X	23,9	5 <sup>3</sup> / <sub>8</sub> - 4 <sup>5</sup> / <sub>8</sub>	W22506R410	5 <sup>3</sup> / <sub>8</sub> - 4 <sup>1</sup> / <sub>4</sub>	W22506R404	5 <sup>3</sup> / <sub>8</sub> - 4 <sup>1</sup> / <sub>8</sub>	W22506R402	-	-	
-	-	-	W22506X	23,9	5 <sup>3</sup> / <sub>8</sub> - 3 <sup>7</sup> / <sub>8</sub>	W22506R314	-	-	-	-	-	-	

<sup>1)</sup> See page 82 for table of hexagon sizes of bolts, nuts and related thread diameters.

# W35000X, Inch-Cassettes & Reducer Inserts

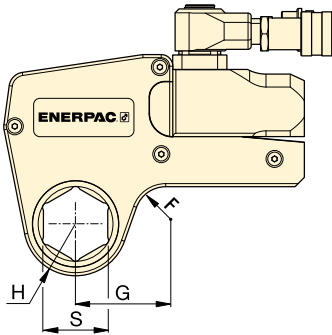

## ▼ SELECTION CHART

Drive Unit Model Number	Hexagon Size S	Nose Radius H	G	Model Nr. Cassette	Weight (kg)	Reducer	
						Hexagon Reducer (inch)	Model Number Reducer
W35000X	3 1/8	76,0	126,8	W35302X	32,8	3 1/8 - 2	W35302R200
	3 3/16	76,0	126,8	W35303X	32,7	-	-
	3 1/4	76,0	126,8	W35304X	32,5	-	-
	3 5/16	76,0	126,8	W35305X	32,4	-	-
	3 3/8	76,0	126,8	W35306X	32,2	-	-
	3 7/16	76,0	126,8	W35307X	32,0	-	-
	3 1/2	76,0	126,8	W35308X	31,8	3 1/2 - 2 5/16	W35308R205
	3 9/16	81,5	132,5	W35309X	32,4	-	-
	3 5/8	81,5	132,5	W35310X	33,3	-	-
	3 11/16	81,5	132,5	W35311X	33,1	-	-
	3 3/4	81,5	132,5	W35312X	32,9	-	-
	3 13/16	81,5	132,5	W35313X	32,7	-	-
	3 7/8	81,5	132,5	W35314X	32,4	3 7/8 - 2 11/16	W35314R211
	3 15/16	87,0	137,0	W35315X	34,1	3 15/16 - 2 13/16	W35315R213
	4	87,0	137,0	W35400X	33,9	-	-
	4 1/16	87,0	137,0	W35401IX	33,7	-	-
	4 1/8	87,0	137,0	W35402X	33,5	-	-
	4 3/16	87,0	137,0	W35403IX	33,3	-	-
	4 1/4	87,0	137,0	W35404X	33,0	4 1/4 - 3 1/16	W35404R301
	4 5/16	93,0	143,0	W35405X	34,9	-	-
	4 3/8	93,0	143,0	W35406X	34,7	-	-
	4 7/16	93,0	143,0	W35407X	34,5	-	-
	4 1/2	93,0	143,0	W35408X	34,3	-	-
	4 9/16	93,0	143,0	W35409X	34,1	-	-
	4 5/8	93,0	143,0	W35410IX	33,7	4 5/8 - 3 5/8	W35410R310
	4 3/4	98,5	148,5	W35412X	35,6	4 3/4 - 3 3/4	W35412R312
	4 7/8	98,5	148,5	W35414X	34,9	-	-
	5	98,5	148,5	W35500X	34,3	5 - 4	W35500R400
	5 1/8	103,0	153,0	W35502X	35,8	5 1/8 - 4 1/8	W35502R402
	5 3/16	103,0	153,0	W35503IX	35,6	-	-
	5 1/4	103,0	153,0	W35504X	35,2	-	-
	5 3/8	103,0	153,0	W35506X	34,6	5 3/8 - 4 5/16	W35506R405
5 1/2	108,5	158,5	W35508X	36,2	-	-	
5 9/16	108,5	158,5	W35509X	36,0	-	-	
5 5/8	108,5	158,5	W35510X	35,6	-	-	
5 3/4	108,5	164,0	W35512X	34,9	5 3/4 - 4 3/4	W35512R412	
5 7/8	114,0	164,0	W35514X	36,7	5 7/8 - 4 7/8	W35514R414	
6	114,0	164,0	W35600X	36,1	-	-	
6 1/8	114,0	164,0	W35602X	35,3	6 1/8 - 5 1/8	W35602R502	

## W Series X-Edition



Maximum Torque at 690 bar:

**47.454 Nm**

Hexagon Range:

**3 1/8 - 6 1/8 inch**

Maximum Operating Pressure:

**690 bar**



### Hexagon Bolt and Nut Sizes

See the table for hexagon sizes of bolts, nuts and related thread diameters.

Page: 82

# W-Series, Metric Cassettes and Reducers

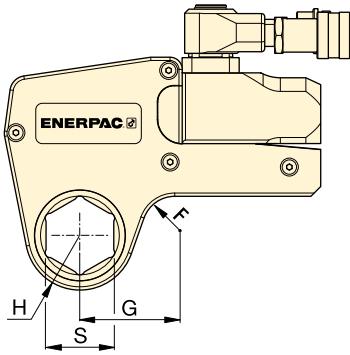

Hexagon Range:  
**24 - 105 mm**

Maximum Operating Pressure:  
**690 bar**

**W**  
Series  
X-Edition



▼ SELECTION CHART

Drive Unit Model Number	Hexagon Size <sup>1)</sup>	Nose Radius	Dim.	Model Nr. Cassette	Weight (kg)	Hexagon Reducer		Hexagon Reducer		Hexagon Reducer		
						Hexagon Reducer (mm)	Model Number Reducer	Hexagon Reducer (mm)	Model Number Reducer	Hexagon Reducer (mm)	Model Number Reducer	
<b>W2000X</b> (2766 Nm)	26	31	54	W2102X	2,1	-	-	-	-	-	-	
	30	31	54	W2103X	2,1	-	-	-	-	-	-	
	32	31	54	W2104X	2,1	-	-	-	-	-	-	
	36	31	54	W2107X	2,1	-	-	-	-	-	-	
	38	34	58	W2108X	2,1	-	-	-	-	-	-	
	41	34	58	W2110X	2,1	41 - 32	W2110R104	41 - 30	W2110R103	41 - 24	W2110R024M	
	46	34	61	W2113X	2,2	46 - 36	W2113R107	46 - 32	W2113R104	-	-	
	50	39	63	W2200X	2,2	50 - 41	W2200R110	50 - 36	W2200R107	-	-	
	55	42	69	W2203X	2,2	55 - 46	W2203R113	55 - 41	W2203R110	55 - 36	W2203R107	
	60	45	65	W2206X	2,2	60 - 50	W2206R200	60 - 46	W2206R113	60 - 41	W2206R110	
-	-	-	-	-	-	60 - 36	W2206R107	-	-	-		
<b>W4000X</b> (5661 Nm)	33	37	61	W4105X	3,7	-	-	-	-	-	-	
	35	37	61	W4106X	3,7	-	-	-	-	-	-	
	36	37	61	W4107X	3,7	-	-	-	-	-	-	
	41	37	61	W4110X	3,7	-	-	-	-	-	-	
	46	40	64	W4113X	3,8	-	-	-	-	-	-	
	50	42	67	W4200X	3,9	50 - 36	W4200R107	-	-	-	-	
	55	44	73	W4203X	4,0	55 - 41	W4203R110	55 - 36	W4203R107	55 - 32	W4203R104	
	60	47	71	W4206X	4,1	60 - 50	W4206R200	60 - 46	W4206R113	60 - 36	W4206R107	
	65	50	76	W4209X	4,1	65 - 55	W4209R203	65 - 50	W4209R200	65 - 46	W4209R113	
	70	53	78	W4212X	4,2	70 - 60	W4212R206	70 - 55	W4212R203	-	-	
	75	55	82	W4215X	4,3	75 - 65	W4215R209	75 - 60	W4215R206	-	-	
	-	-	-	-	-	-	75 - 55	W4215R203	75 - 50	W4215R200	-	-
	80	59	84	W4302X	4,4	80 - 75	W4302R215	80 - 70	W4302R212	80 - 65	W4302R209	
-	-	-	-	-	-	80 - 55	W4302R203	80 - 50	W4302R200	-	-	
85	62	86	W4085MX	4,5	-	-	-	-	-	-		
<b>W8000X</b> (11.484 Nm)	48	45	78	W8114X	8,1	-	-	-	-	-	-	
	49	45	78	W8115X	8,1	-	-	-	-	-	-	
	50	45	78	W8200X	8,1	-	-	-	-	-	-	
	55	48	80	W8203X	8,1	-	-	-	-	-	-	
	60	51	83	W8206X	8,1	-	-	-	-	-	-	
	65	56	85	W8209X	8,1	65 - 50	W8209R200	-	-	-	-	
	70	56	85	W8212X	7,9	70 - 55	W8212R203	-	-	-	-	
	75	58	85	W8215X	7,9	75 - 60	W8215R206	75 - 55	W8215R203	-	-	
	80	61	90	W8302X	8,0	80 - 65	W8302R209	80 - 60	W8302R206	80 - 55	W8302R203	
	-	-	-	-	-	-	80 - 50	W8302R200	-	-	-	
	85	66	92	W8085MX	8,2	85 - 70	W8085R070M	85 - 65	W8085R065M	85 - 60	W8085R060M	
	-	-	-	-	-	-	85 - 55	W8085R055M	-	-	-	
	90	74	103	W8090MX	8,8	90 - 75	W8090R075M	-	-	-	-	
	95	74	103	W8312X	8,8	95 - 80	W8312R302	95 - 75	W8312R215	-	-	
100	80	110	W8315X	9,3	-	-	-	-	-	-		
105	80	110	W8402X	9,3	-	-	-	-	-	-		

<sup>1)</sup> See page 82 for table of hexagon sizes of bolts, nuts and related thread diameters.

# W-Series, Metric Cassettes and Reducers

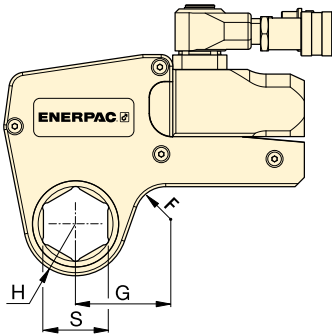

Hexagon Range:

**50 - 155 mm**

Maximum Operating Pressure:

**690 bar**

**W**  
Series  
X-Edition



## ▼ SELECTION CHART

Drive Unit Model Number	Hexagon Size <sup>1)</sup>	Nose Radius	Dim.	Model Nr. Cassette	Weight (kg)	Reducer		Reducer	
						Hexagon Reducer (mm)	Model Number Reducer	Hexagon Reducer (mm)	Model Number Reducer
<b>W15000X</b> (20.785 Nm)	62	59	89	W15207X	13,6	-	-	-	-
	63	59	89	W15208X	13,6	-	-	-	-
	65	59	89	W15209X	13,6	-	-	-	-
	70	59	89	W15212X	13,6	-	-	-	-
	75	62	91	W15215X	13,7	-	-	-	-
	80	65	93	W15302X	13,8	80 - 65	W15302R209	-	-
	85	70	97	W15085MX	14,1	85 - 70	W15085R070M	-	-
	90	75	102	W15090MX	14,5	90 - 75	W15090R75M	-	-
	95	75	102	W15312X	14,6	95 - 80	W15312R302	95 - 75	W15312R215
	100	81	103	W15315X	14,8	-	-	-	-
	105	81	103	W15402X	14,8	105 - 90	W15402R090M	-	-
	110	88	115	W15405X	15,1	110 - 95	W15110R095M	-	-
115	88	115	W15115MX	15,1	115 - 100	W15115R100M	-	-	
<b>W22000X</b> (30.506 Nm)	75	67	102	W22215X	22,0	-	-	-	-
	80	67	102	W22302X	21,6	80-60	W22302R206	80 - 55	W22302R203
	85	73	107	W22085MX	22,5	85-65	W22085MR209	85 - 60	W22085MR206
	90	78	113	W22090MX	23,4	90-70	W22090M212	90 - 60	W22090MR206
	95	78	113	W22312X	22,9	95-75	W22312R215	-	-
	100	85	120	W22315X	24,3	-	-	-	-
	105	85	120	W22402X	23,4	-	-	-	-
	110	90	125	W22405X	24,6	-	-	-	-
	115	90	125	W22115MX	24,0	-	-	-	-
	120	95	130	W22412X	24,7	-	-	-	-
	123	95	130	W22123MX	24,4	-	-	-	-
	130	100	135	W22502X	25,0	-	-	-	-
135	100	135	W22506X	23,9	135 - 105	W22506R402	-	-	
<b>W35000X</b> (47.454 Nm)	80	77	129	W35302X	32,8	80 - 50	W35302R200	-	-
	85	77	129	W35085MX	32,3	-	-	-	-
	90	82	135	W35090MX	33,5	90 - 60	W35090R206	-	-
	95	82	135	W35312X	32,9	-	-	-	-
	100	88	139	W35315X	34,1	-	-	-	-
	105	88	139	W35402X	33,5	-	-	-	-
	110	94	146	W35405X	34,9	110 - 85	W35405R085M	-	-
	115	94	146	W35115MX	34,2	-	-	-	-
	120	100	153	W35412X	35,6	120 - 95	W35412R312	-	-
	123	100	153	W35123MX	35,0	-	-	-	-
	130	104	160	W35502X	35,8	130 - 105	W35502R402	-	-
	135	104	160	W35506X	34,6	135 - 110	W35506R405	-	-
	140	110	163	W35508X	36,2	140 - 115	W35508R115M	-	-
	145	110	163	W35512X	34,9	145 - 120	W35512R412	-	-
	150	115	169	W35514X	36,7	-	-	-	-
151	115	169	W35151MX	36,5	-	-	-	-	
155	115	169	W35602X	35,3	155 - 130	W35602R502	-	-	

<sup>1)</sup> See page 82 for table of hexagon sizes of bolts, nuts and related thread diameters.

# W-Series, UltraSlim Bi-Hexagonal Cassettes

**ENERPAC**   
POWERFUL SOLUTIONS. GLOBAL FORCE.

▼ W4206SL bi-hexagonal cassette with W4000X drive unit



## Versatility

- Lean, stepped width design allows tool to be mounted over bolts where other tools won't fit
- Bi-Hexagonal cassette allows twice as many positioning points on nut or bolt
- Robust top mounted handle stays out of the way, providing safe fastening in hard to reach areas
- Uses same drive unit as standard W-series hexagon cassettes

## Performance

- Premium components provide best-in-class endurance compared to other limited access tools

## Ease of Use

- Few moving parts are easily accessible for quick field maintenance
- Fast release drive unit enables rapid exchange of cassettes, no tools required
- Top mounted straight handle for improved tool handling and safety

## Accuracy

- Constant torque output provides accuracy of  $\pm 3\%$  across the full stroke
- Calibration certificate shipped with every cassette.

**Your easy and long lasting solution to difficult access bolting applications**



### UltraSlim: Designed for Tight Spots

Stepped width design provides easy access in confined areas. UltraSlim cassettes fit where standard solutions won't.



### Built to Outperform

High endurance components keep working when others fail.



### Top Mounted Straight Handle

The top mounted straight handle is standard and provides safe and easy positioning and access to hard to reach fasteners.

Straight handle (standard)	<b>SWH6S</b>
Angled handle (optional)	<b>SWH6A</b>



### ATEX declared. Calibration certificate included.

All UltraSlim Series cassettes are CE - ATEX declared and are shipped complete with a calibration certificate.

  II 2 GD T4



*Slim enough to fit and tough enough to last.  
This UltraSlim wrench is the perfect controlled  
bolting solution for this oil and gas flange. ►*



# UltraSlim Stepped Width Cassettes



## UltraSlim Bi-Hexagonal Cassettes

Accessing narrow spaces normally requires significantly reducing the width of the torque wrench. For the tool operator, this has always meant vastly reduced tool durability, and/or reduced torque output.

By using the highest grade materials, perfecting the geometry, and placing the positioning handle on top of the tool for safe fastening, Enerpac UltraSlim cassettes are able to provide greater torque, get into tighter spaces, and vastly outperform the competition in product durability\*.

## Durability of Key Components \*

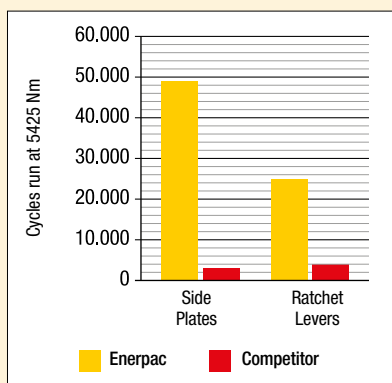

\* Average test results, whereby three Enerpac 46 mm UltraSlim cassettes and three competitor 46 mm cassettes were tested at 5425 Nm for 50,000 cycles. The Enerpac side plates never broke for the full duration of the test.

## W-SL Series UltraSlim



Maximum Torque Output:

**5911 Nm**

Bi-Hexagonal Range:

**46 - 75 mm**

Maximum Operating Pressure:

**690 bar**



## Torque Wrench Pumps Selection Matrix

Visit [enerpac.com](http://enerpac.com) for system matched air and electric torque wrench pumps that are ideal for use with hydraulic torque wrenches.

Page: 40

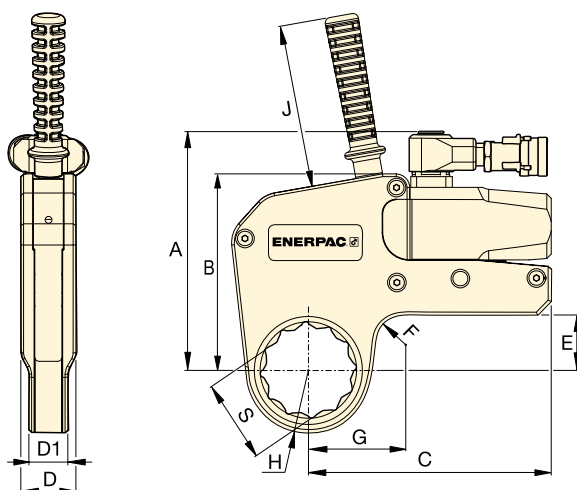

## Torque Wrench Hoses

Use Enerpac THQ-700 Series torque wrench hoses with W-Series torque wrenches to ensure the integrity of your hydraulic system.

6 m long, 2 hoses	<b>THQ-706T</b>
12 m long, 2 hoses	<b>THQ-712T</b>

## SELECTION CHART

Bi-Hexagonal Size	Maximum Torque @ 690 bar	UltraSlim Cassette * Model Nr.	Minimum Torque @ 69 bar	Nose Radius	Dimensions (mm)										Drive Unit Model Nr. ** (sold separately)																
					H	G	A	B	C	D	D1	E	F	J		(kg)															
S (mm) (inch)	(Nm)		(Nm)	H (mm)	G	A	B	C	D	D1	E	F	J	(kg)																	
																46	1 <sup>3</sup> / <sub>16</sub>	2685	<b>W2113SL</b>	271	36,5	59,6	140,7	109,3	147,7	32,4	25,4	24,0	20,0	120	2,2
																55	2 <sup>3</sup> / <sub>16</sub>	2685	<b>W2203SL</b>	271	41,5	63,2									2,2
60	2 <sup>3</sup> / <sub>8</sub>	2685	<b>W2206SL</b>	271	44,5	65,1	175,6	144,5	178,5	40,5	28,6	40,8	20,0	120	4,6	<b>W4000X</b>															
55	2 <sup>3</sup> / <sub>16</sub>	5911	<b>W4203SL</b>	583	44,0	68,7											4,7														
60	2 <sup>3</sup> / <sub>8</sub>	5911	<b>W4206SL</b>	583	48,0	71,6	175,6	144,5	178,5	40,5	28,6	40,8	20,0	120	4,7	<b>W4000X</b>															
65	2 <sup>3</sup> / <sub>16</sub>	5911	<b>W4209SL</b>	583	50,5	74,1											4,7														
70	2 <sup>3</sup> / <sub>4</sub>	5911	<b>W4212SL</b>	583	53,5	75,6	175,6	144,5	178,5	40,5	28,6	40,8	20,0	120	4,7	<b>W4000X</b>															
75	2 <sup>15</sup> / <sub>16</sub>	5911	<b>W4215SL</b>	583	56,0	76,0											4,7														

\* Bi-Hexagonal Cassette includes top mounted straight handle.

\*\* Cassette may also be used with W2000PX and W4000PX drive units, featuring double-swivel manifolds. Weight of drive unit W2000X = 1,4 kg; W4000X = 2,0 kg.

# WCR-Series, Roller Cassette Torque Wrench

▼ WCR4000 Roller Cassette with Spanner and W4000X Drive Unit



- Provides a safe and reliable controlled bolting solution for flanges with limited access
- Spanners available to fit most commonly used API flanges
- Small nose radius – resolves bolt to pipe restrictions
- Slim spanner design – reduces bolt height restrictions
- Wide range of spanners ranging from 36 - 80 mm (1<sup>7</sup>/<sub>16</sub> - 3<sup>1</sup>/<sub>8</sub> inch)
- Includes handle to improve tool handling and safety
- Rigid steel body for maximum endurance and minimum downtime.

Bi-Hexagonal Spanner Size:

**36 - 80 mm, 1<sup>7</sup>/<sub>16</sub> - 3<sup>1</sup>/<sub>8</sub>"**

Spanner Nose Radius:

**31 - 55 mm**

Maximum Torque:

**5762 Nm (4250 Ft.lbs)**

Maximum Operating Pressure:

**690 bar**





### WCR-4000 Applications

The WCR4000 helps resolve narrow clearance restrictions in bolting of API and BOP flanges.

The Enerpac WCR4000 Roller Cassette has been developed for applications where there are severe clearance restrictions, particularly in height above the nut or between the bolt center and the inside of the joint.

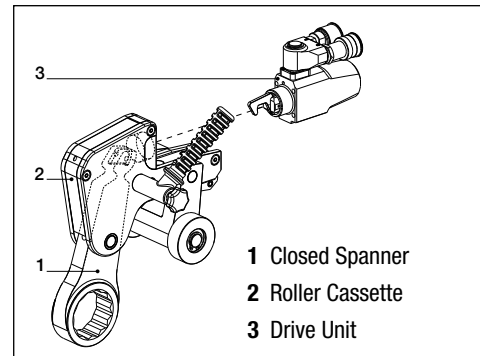
Powered by the standard W4000X drive unit which is compatible with standard W-Series hexagon cassettes. The WCR-wrench must be removed and repositioned after each wrench cycle by operating the pump in the retract direction. The tool contains no spring return.



Closed Spanner Hexagon Size S (inch)   (mm)	Closed Spanner Model Number	Maximum Torque (Nm)	Spanner Radius R (mm)	 * (kg)	Roller Cassette Assembly Model Nr.	Drive Unit Model Nr.
1 <sup>7</sup> / <sub>16</sub>   36	W4107CS	5762	31	1,9	WCR4000	W4000X
1 <sup>1</sup> / <sub>2</sub>   38	W4108CS	5762	33	2,0		
1 <sup>5</sup> / <sub>8</sub>   41	W4110CS	5762	33	1,9		
1 <sup>3</sup> / <sub>16</sub>   46	W4113CS	5762	36	1,9		
1 <sup>7</sup> / <sub>8</sub>   48	W4114CS	5762	38	2,1		
2   50	W4200CS	5762	38	1,9		
2 <sup>3</sup> / <sub>16</sub>   55	W4203CS	5762	41	2,0		
2 <sup>3</sup> / <sub>8</sub>   60	W4206CS	5762	45	2,1		
2 <sup>9</sup> / <sub>16</sub>   65	W4209CS	5762	47	2,1		
2 <sup>3</sup> / <sub>4</sub>   70	W4212CS	5762	50	2,1		
2 <sup>15</sup> / <sub>16</sub>   75	W4215CS	5762	52	2,1		
3 <sup>1</sup> / <sub>8</sub>   80	W4302CS	5762	55	2,2		

\* Spanner weight. For total weight add 6,3 kg for WCR4000 and 2,0 kg for W4000X.

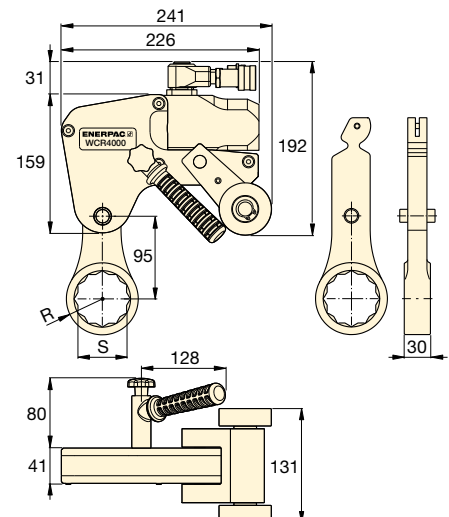

# Accessories for W-Series, X-Edition Wrenches

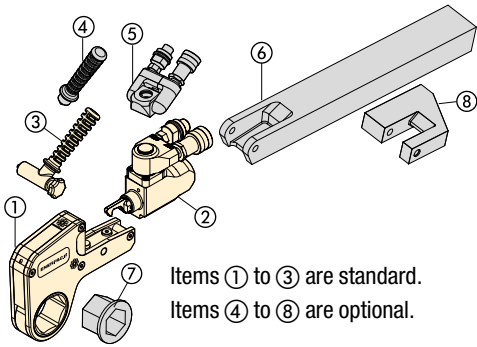

Items ① to ③ are standard.  
Items ④ to ⑧ are optional.

- ① Hexagon Cassette
- ② Drive Unit
- ③ Angled Positioning Handle
- ④ Straight Positioning Handle
- ⑤ Pro Series Swivel
- ⑥ Extended Reaction Arm
- ⑦ Reducer Insert
- ⑧ Reaction Paddle

## TSP WTE WRP Series



### TSP-Series, Pro Series Swivel

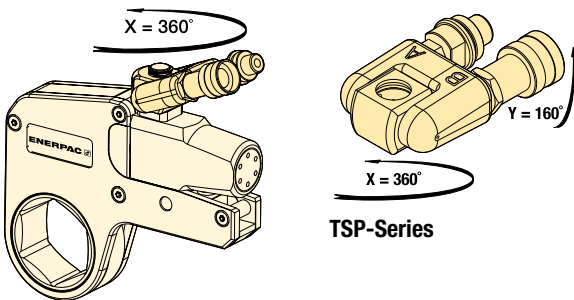

- Robust interlocking design
- 360° X-axis and 160° Y-axis rotation
- Increases tool fit in restricted access areas
- Simplifies hose placement
- Includes male and female couplers.

For Torque Wrench Model Number	Model Number <sup>1)</sup>	Maximum Pressure (bar)	Weight (kg)
W2000X, W4000X, W8000X, W15000X, W22000X, W35000X	TSP300	690	0,2

<sup>1)</sup> To order a W-Series (X-edition) drive unit fitted with a TSP300 tilt and swivel manifold, insert a "P" prior to the "X" in the tool model number, example: **W2000PX**.  
TSP300 is designed for X-Edition tools only, and is not compatible with standard edition tools.  
For replacement components for existing tools, refer to repair sheet on [www.enerpac.com](http://www.enerpac.com)

### WTE-Series, Extended Reaction Arms

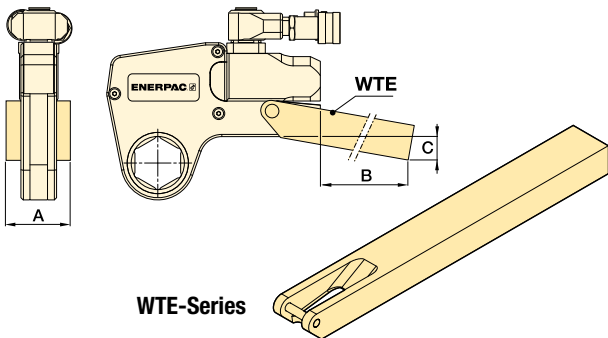

- Full torque rated
- Increases tool fit in restricted access areas.

For Torque Wrench Model Number	Model Number	Dimensions (mm)			Weight (kg) *
		A	B	C	
W2000X	WTE20	56	398	76	2,6
W4000X	WTE40	66	436	74	4,6
W8000X	WTE80	85	449	55	7,6
W15000X	WTE150	102	498	72	12,0
W22000X	WTE220	114	524	77	17,3
W35000X	WTE350	127	419	133	17,8

\*Weights indicated are for the accessories only and do not include the wrench.

### WRP-Series, Reaction Paddles

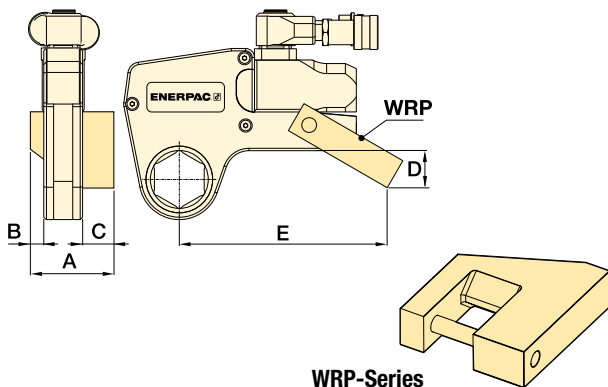

- Lightweight interchangeable design
- Allows for offset reaction when in-line reaction is not available.

For Torque Wrench Model Nr.	Model Number	Dimensions (mm)					Weight (kg) *
		A	B	C	D	E	
W2000X	WRP20	84	16	35	45	148	0,4
W4000X	WRP40	109	21	47	59	190	0,8
W8000X	WRP80	137	26	57	69	223	2,0
W15000X	WRP150	165	32	69	87	257	3,9
W22000X	WRP220	207	37	91	134	317	7,2
W35000X	WRP350	225	42	91	182	367	10,6

\*Weights indicated are for the accessories only and do not include the wrench.

▼ Shown: SQD-50-I



## Lightweight Aluminium High-Power Wrench for Sockets or Allen Drives

- Very high torque-to-weight ratio
- High speed, double-acting operation
- High degree of rotation angle for increased productivity
- Never-jam mechanism
- High repeatability, with accuracy  $\pm 3\%$
- Slim nose radius and 360° swivel hose connection allow easier positioning in confined areas
- Few moving parts means durability and low maintenance
- Push-button drive release; no tools needed to reverse square or Allen drives for tightening or loosening
- Storage case (included) protects from damage, water and dirt
- Lock-ring couplers are standard on all torque wrenches, pumps and hoses.



◀ Easy and reliable service in the field using Enerpac SQD-Series torque wrenches.



### Swivel Hose Connection

All Enerpac torque wrenches feature a 360° swivel connection to allow easy access in all positions.



### Twin 3,5:1 Safety Hoses

Use only Enerpac THC-700 series twin 3,5:1 safety hoses with SQD-Series double-acting wrenches to ensure the integrity of your system.

Length 6 m, 2 hoses	<b>THC-7062</b>
Length 12 m, 2 hoses	<b>THC-7122</b>



### Optional Allen-Key Drives

Expanded versatility with a wide range of metric and imperial Allen-Key drives.

# Double-Acting, Square Drive Hydraulic Wrenches



▲ All wrenches come standard with swivel coupler, square drive and reaction arm.

## SQD Series



Maximum Torque:  
**27.000 Nm**

Square Drive Range:  
**3/4 - 2 1/2 inch**

Maximum Operating Pressure:  
**800 bar**

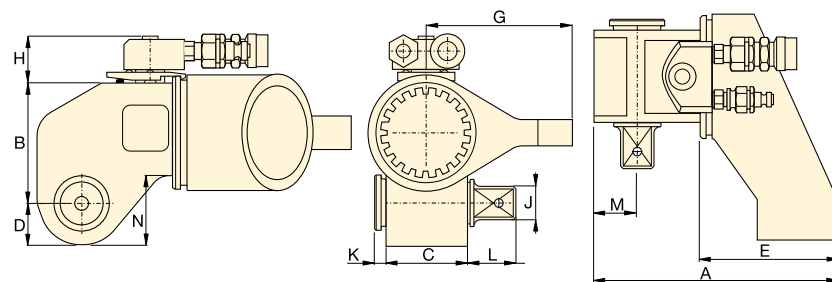
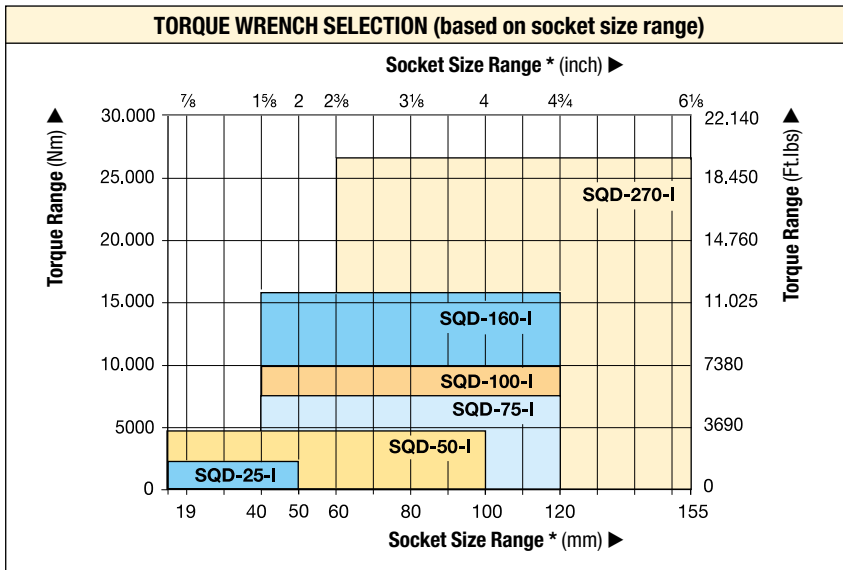

Use only heavy-duty Impact Sockets for power driven torquing equipment, according to ISO 2725 and ISO 1174; DIN 3129 and DIN 3121 or ASME-B107.2/1995.

Page: 10



### Torque Wrench Pumps and Hoses

Enerpac system matched air and electric torque wrench pumps provide control to operate hydraulic torque wrenches.

Page: 40



### Hexagon Bolt and Nut Sizes

See the table for hexagon sizes of bolts, nuts and related thread diameters.

Page: 82

### SELECTION CHART

Square Drive Size (inch)	Maximum Torque @ 800 bar		Torque Wrench Model Number	Dimensions (mm)											Weight (including reaction arm and square drive) (kg)	
	(Nm)	(Ft.lbs)		A	B	C	D	E	G	H	J	K	L	M		N
3/4	2350	1735	SQD-25-I	167	72	53	24	108	95	35	3/4	6	28	27	36	2,5
1	4800	3550	SQD-50-I	204	92	68	31	135	115	35	1	15	33	34	52	4,3
1 1/2	7560	5570	SQD-75-I	226	107	76	36	153	122	35	1 1/2	12	43	39	64	6,7
1 1/2	10.000	7360	SQD-100-I	253	115	84	39	164	130	35	1 1/2	13	39	43	68	8,0
1 1/2	16.000	11.835	SQD-160-I	272	134	100	48	178	150	50	1 1/2	11	45	54	81	12,0
2 1/2	27.000	19.875	SQD-270-I	342	164	119	59	218	200	50	2 1/2	18	76	63	99	24,5

\* See page 10 for BSH-series Heavy-Duty Impact Sockets.

▼ SELECTION CHART

TORQUE WRENCH		OPTIONAL ALLEN-KEY DRIVES, IMPERIAL			REACTION ARM FOR ALLEN DRIVE
Model Number (max. capacity)	Nose Radius D (mm)	Hexagon Size (inch)	Maximum Torque (Nm)	Model Number	Model Number
SQD-25-I (2350 Nm)	24	1/2	530	25A-050	RAH-25
		5/8	1000	25A-063	
		3/4	1800	25A-075	
		7/8	2350	25A-088	
		1	2350	25A-100	
SQD-50-I (4800 Nm)	31	5/8	1000	50A-063	RAH-50
		3/4	1800	50A-075	
		7/8	2800	50A-088	
		1	4200	50A-100	
		1 1/8	4800	50A-113	
		1 1/4	4800	50A-125	
		-	-	-	
SQD-75-I (7560 Nm)	31	5/8	1000	75A-063	RAH-75
		3/4	1800	75A-075	
		7/8	2800	75A-088	
		1	4200	75A-100	
		1 1/8	5900	75A-113	
		1 1/4	7560	75A-125	
		-	-	-	
SQD-100-I (10.000 Nm)	39	7/8	2800	100A-088	RAH-100
		1	4200	100A-100	
		1 1/8	5900	100A-113	
		1 1/4	8500	100A-125	
		1 3/8	10.000	100A-138	
SQD-160-I (16.000 Nm)	48	1 1/2	10.000	100A-150	RAH-160
		1 3/8	10.500	160A-138	
		1 1/2	14.000	160A-150	
		1 5/8	16.000	160A-163	
		1 3/4	16.000	160A-175	
SQD-270-I (27.000 Nm)	59	1 1/2	14.000	270A-150	RAH-270
		1 5/8	18.000	270A-163	
		1 3/4	22.000	270A-175	
		1 7/8	27.000	270A-188	
		2	27.000	270A-200	
		2 1/4	27.000	270A-225	
		-	-	-	
		-	-	-	

## For SQD Series



Maximum Torque at 800 bar:

**27.000 Nm**

Allen Drive Range:

**1/2 - 2 1/4 inch**

Nose Radius:

**24 - 59 mm**



### Torque Wrench Pumps and Hoses

Enerpac system matched air and electric torque wrench pumps provide control to operate hydraulic torque wrenches.

Page: **40**



### NS and NC-Series Nut Splitters

Remove rusted or corroded nuts easily with Enerpac Nut Cutters. Cuts hexagon nut sizes up to 130 mm.

Page: **65**



### Hexagon Bolt and Nut Sizes

See the table for hexagon sizes of bolts, nuts and related thread diameters.

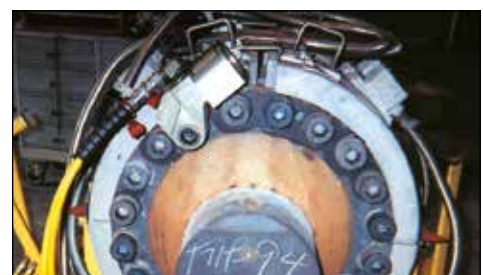

Page: **82**

▼ SQD-100-I with RAH-100 Reaction Arm and Allen drive used for loosening hexagon socket head cap screws.

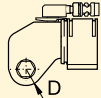

# SQD-Series, Metric Allen-Key Drives

## ▼ SELECTION CHART

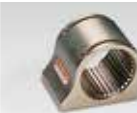
TORQUE WRENCH		OPTIONAL ALLEN-KEY DRIVES, METRIC			REACTION ARM FOR ALLEN DRIVE
					
Model Number (max. capacity)	Nose Radius D (mm)	Hexagon Size (mm)	Maximum Torque (Nm)	Model Number	Model Number
SQD-25-I (2350 Nm)	24	14	750	25A-14	RAH-25
		17	1300	25A-17	
		19	1800	25A-19	
		22	2350	25A-22	
		24	2350	25A-24	
SQD-50-I (4800 Nm)	31	17	1300	50A-17	RAH-50
		19	1800	50A-19	
		22	2800	50A-22	
		24	3500	50A-24	
		27	4800	50A-27	
		30	4800	50A-30	
		32	4800	50A-32	
SQD-75-I (7560 Nm)	31	17	1300	75A-17	RAH-75
		19	1800	75A-19	
		22	2800	75A-22	
		24	3500	75A-24	
		27	5000	75A-27	
		30	7000	75A-30	
		32	7560	75A-32	
SQD-100-I (10.000 Nm)	39	22	2800	100A-22	RAH-100
		24	3500	100A-24	
		27	5000	100A-27	
		30	7000	100A-30	
		36	10.000	100A-36	
SQD-160-I (16.000 Nm)	48	30	7000	160A-30	RAH-160
		32	8500	160A-32	
		36	12.000	160A-36	
		41	16.000	160A-41	
		46	16.000	160A-46	
SQD-270-I (27.000 Nm)	59	36	12.000	270A-36	RAH-270
		41	18.000	270A-41	
		46	25.000	270A-46	
		50	27.000	270A-50	
		55	27.000	270A-55	
		60	27.000	270A-60	
		70	27.000	270A-70	

## For SQD Series



Maximum Torque at 800 bar:

**27.000 Nm**

Allen Drive Range:

**14 - 70 mm**

Nose Radius:

**24 - 59 mm**



### Optional Allen-Key Drives and Reaction Arm

The RAH-Reaction Arm for Allen drives must be used instead of reaction arm for square drives.



### Flange Spreaders

Separates pipe flanges with ease, enabling efficient maintenance tasks.

Page: **68**



### Select the Right Torque

Choose your Enerpac Torque Wrench using the loosening torque rule of thumb: Loosening torque may require 250% of tightening torque depending on the condition of the fastener.

▼ SQD-50-I with 50A-22 Allen drive with RAH-50 Reaction Arm for Allen drives.



▼ HXD-60 with CC-680



- High torque-to-weight ratio, slim nose radius and flat design
- High speed, high degree of rotation angle
- Snap in, interchangeable cassettes, no tools required
- 360° swivel hose connection allows easier positioning in confined areas
- High repeatability, with accuracy  $\pm 3\%$
- Strong unibody design, integrated reaction arm and few moving parts make wrenches durable and reliable
- Extensive range of metric and imperial hexagon cassettes and reducers
- Drive unit and cassette come in storage case to protect from damage, water and dirt
- Lock-ring couplers are standard.

## Aluminium, Low Profile



### Twin 3,5:1 Safety Hoses

Use only Enerpac THC-700 series twin 3,5:1 safety hoses with HXD double-acting wrenches to ensure the integrity of your system.

Page: 40



### Nut Cutters

Remove rusted or corroded nuts easily with Enerpac Nut Cutters. Cuts hexagon nut sizes up to 130 mm.

Page: 65



### Select the Right Torque

Choose your Enerpac Torque Wrench using the loosening torque rule of thumb: Loosening torque may require 250% of tightening torque depending on the condition of the fastener.

Page: 79



◀ Easy and reliable service in the field using Enerpac HXD-Series torque wrenches.



# Double-Acting Hydraulic Torque Wrenches

▼ Shown from left to right: CC-3238, HXD-30



## Torque Wrench Selection in 2 steps:

- 1. Drive Unit**  
Select the HXD-drive Unit using the quick selection chart below.
- 2. Cassette**  
Select the appropriate cassette from pages 32-33.

## HXD Series



Maximum Torque:  
**24.210 Nm**

Hexagon Range:  
**32-130 mm | 1¼-5 inch**

Nose Radius:  
**28,5 - 96,0 mm**

Maximum Operating Pressure:  
**800 bar**

### DRIVE UNIT AND INTERCHANGEABLE CASSETTE SELECTION

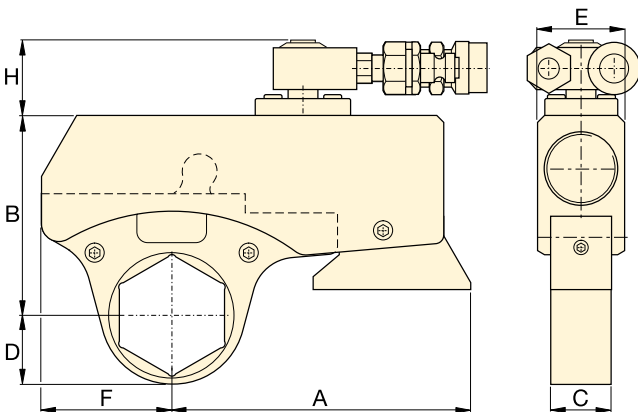
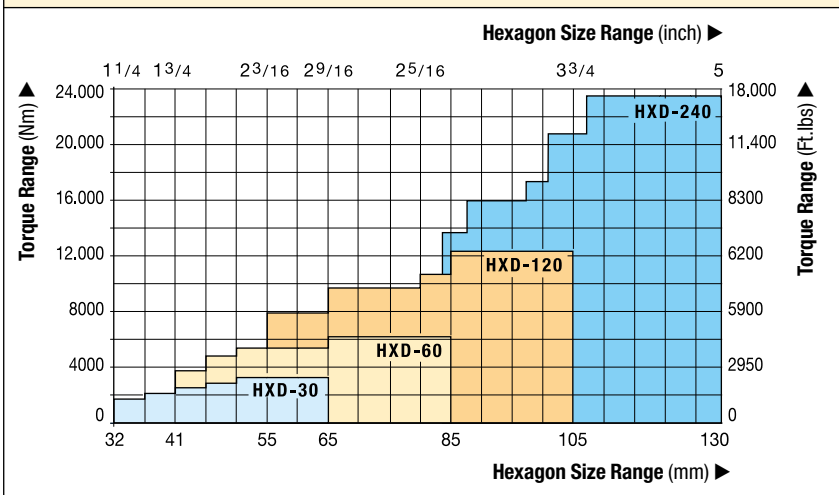

HXD-Drive Unit with CC-Hexagon Cassette

### ▼ QUICK SELECTION CHART

Cassette Range		Maximum Torque at 800 bar (Nm)	Drive Unit * Model Number	Drive Unit and Cassette Dimensions (mm)							Weight (including smallest cassette) (kg)
(mm)	(inch)			A	B	C	D	E	F	H	
32 - 60	1¼ - 2¾	3290	HXD-30	135	91 - 103	28	28,5 - 47,5	40	60	38	1,6
41 - 80	1⅝ - 3⅛	6190	HXD-60	156	115 - 130	35	34,5 - 60,5	50	75	38	2,5
55 - 100	2¾/16 - 3¾/8	12.500	HXD-120	200	141 - 156	47	46,5 - 73,5	65	96	38	4,8
80 - 130	3⅜ - 5	24.210	HXD-240	259	182 - 202	56	62,0 - 96,0	82	125	50	8,2

\* With integrated reaction arm.



**Metric and Imperial Sizes**  
Expanded versatility with the full range of metric and imperial hexagon Reducer Inserts.

Page: 32



**Hexagon Bolt and Nut Sizes**  
See the table for hexagon sizes of bolts, nuts and related thread diameters.

Page: 82



**Torque Wrench Pumps**  
System matched air and electric pumps provide control to operate Enerpac HXD-Series Torque Wrenches.

Page: 40

# HXD-Series, Inch-Cassettes and Inserts



Maximum Torque at 800 bar:

**24.210 Nm**

Hexagon Range:

**1¼ - 5 inch**





◀ The optional Reducer Insert must be secured in the Cassette with a Holding Ring.

**CC  
IN  
HR  
Series**



▼ SELECTION CHART

DRIVE UNIT 	INTERCHANGEABLE CASSETTE, IMPERIAL					OPTIONAL ADD-ON REDUCER INSERTS, IMPERIAL				HOLDING RINGS
	Max. Torque (Nm)	Hex. Size <sup>1)</sup> (inch)	Nose Radius D (mm)	Model Number	 (kg)	Hexagon Size (inch)	Model Number	Hexagon Size (inch)	Model Number	Model Number
<b>HXD-30</b> (3290 Nm)	1700	1¼	28,5	CC-3125	0,6	-	-	-	-	-
	2100	17/16	31,5	CC-3144	0,7	17/16 - 1¼	IN3144-125	-	-	HR-36
	2500	15/8	34,5	CC-3163	0,7	15/8 - 17/16	IN3163-144	15/8 - 1¼	IN3163-125	HR-41
	2890	113/16	38,5	CC-3181	0,8	113/16 - 15/8	IN3181-163	113/16 - 17/16	IN3181-144	HR-46
	3290	2	42,0	CC-3200	0,9	2 - 113/16	IN3200-181	2 - 15/8	IN3200-163	HR-50
		23/16	45,0	CC-3219	1,0	23/16 - 2	IN3219-200	23/16 - 113/16	IN3219-181	HR-55
	23/8	47,5	CC-3238	1,1	23/8 - 23/16	IN3238-219	23/8 - 2	IN3238-200	HR-60	
<b>HXD-60</b> (6190 Nm)	3840	15/8	34,5	CC-6163	1,2	-	-	-	-	-
	4805	113/16	39,5	CC-6181	1,3	113/16 - 15/8	IN6181-163	-	-	HR-46
	5410	2	43,5	CC-6200	1,4	2 - 113/16	IN6200-181	2 - 15/8	IN6200-163	HR-50
		23/16	46,5	CC-6219	1,5	23/16 - 2	IN6219-200	23/16 - 113/16	IN6219-181	HR-55
		23/8	48,5	CC-6238	1,6	23/8 - 23/16	IN6238-219	23/8 - 2	IN6238-200	HR-60
	6190	23/16	52,5	CC-6256	1,8	23/16 - 23/8	IN6256-238	23/16 - 23/16	IN6256-219	HR-65
		23/4	55,5	CC-6275	1,9	23/4 - 23/16	IN6275-256	23/4 - 23/8	IN6275-238	HR-70
		215/16	57,5	CC-6293	2,0	215/16 - 23/4	IN6293-275	215/16 - 23/16	IN6293-256	HR-75
	31/8	60,5	CC-6313	2,1	31/8 - 215/16	IN6313-293	31/8 - 23/4	IN6313-275	HR-80	
<b>HXD-120</b> (12.500 Nm)	8000	23/16	46,5	CC-12219	2,6	23/16 - 2	IN12219-200	23/16 - 113/16	IN12219-181	HR-55
		23/8	48,5	CC-12238	2,7	23/8 - 23/16	IN12238-219	23/8 - 2	IN12238-200	HR-60
	9800	23/16	52,5	CC-12256	2,7	23/16 - 23/8	IN12256-238	23/16 - 23/16	IN12256-219	HR-65
		23/4	55,5	CC-12275	2,8	23/4 - 23/16	IN12275-256	23/4 - 23/8	IN12275-238	HR-70
		215/16	57,5	CC-12293	2,9	215/16 - 23/4	IN12293-275	215/16 - 23/16	IN12293-256	HR-75
	10.860	3	57,5	CC-12300	2,9	3 - 23/4	IN12300-275	3 - 23/16	IN12300-256	HR-75
		31/8	60,5	CC-12313	3,0	31/8 - 215/16	IN12313-293	31/8 - 23/4	IN12313-275	HR-80
	12.500	33/8	64,5	CC-12338	3,5	33/8 - 3	IN12338-300	33/8 - 215/16	IN12338-293	HR-85
		31/2	67,5	CC-12350	3,6	31/2 - 31/8	IN12350-313	31/2 - 3	IN12350-300	HR-90
		33/4	70,5	CC-12375	3,7	33/4 - 31/2	IN12375-350	33/4 - 33/8	IN12375-338	HR-95
37/8		73,5	CC-12388	3,8	37/8 - 31/2	IN12388-350	37/8 - 33/8	IN12388-338	HR-100	
<b>HXD-240</b> (24.210 Nm)	14.000	31/8	62,0	CC-24313 <sup>2)</sup>	5,1	31/8 - 215/16	IN24313-293	31/8 - 23/4	IN24313-275	HR-80
	15.840	33/8	66,0	CC-24338	5,2	33/8 - 31/8	IN24338-313	33/8 - 3	IN24338-300	HR-85
	16.570	31/2	69,0	CC-24350	5,2	31/2 - 31/8	IN24350-313	31/2 - 3	IN24350-300	HR-90
	17.320	33/4	72,0	CC-24375	5,4	33/4 - 31/2	IN24375-350	33/4 - 33/8	IN24375-338	HR-95
	18.050	37/8	76,0	CC-24388 <sup>3)</sup>	5,6	41/8 - 37/8	IN24413-388	37/8 - 33/8	IN24388-338	HR-100
	21.000	41/8	80,0	CC-24413	5,7	41/8 - 37/8	IN24425-388	41/8 - 33/4	IN24413-375	HR-105
	24.210	41/4	84,0	CC-24425	6,8	41/4 - 41/4	IN24463-425	41/4 - 33/4	IN24425-375	HR-110
		45/8	90,0	CC-24463	7,3	5 - 45/8	IN24500-463	45/8 - 41/8	IN24463-413	HR-120
		5	96,0	CC-24500	7,4	-	-	5 - 41/4	IN24500-425	HR-130

Other Reducer Insert dimensions available upon request.

<sup>1)</sup> See the table of hexagon bolt and nut sizes and related thread diameters on page 82.

<sup>2)</sup> Additional Reducer Insert: 31/8" - 23/16" **IN24313-256** fits **CC-24313** Cassette. Use **HR-80** Holding Ring.

<sup>3)</sup> Additional Reducer Insert: 33/4" - 23/16" **IN24375-313** fits **CC-24388** Cassette. Use **HR-100** Holding Ring.

# HXD-Series, Metric Cassettes and Reducer Inserts



Maximum Torque at 800 bar:

**24.210 Nm**

Hexagon Range:

**32 - 130 mm**









◀ The optional Reducer Insert must be secured in the Cassette with a Holding Ring.

**CC  
IN  
HR  
Series**



## ▼ SELECTION CHART

DRIVE UNIT 	INTERCHANGEABLE CASSETTES, METRIC					OPTIONAL ADD-ON REDUCER INSERTS, METRIC						HOLDING RINGS
	Max. Torque (Nm)	Hex. Size <sup>1)</sup> (mm)	Nose Radius D (mm)	Model Number	 (kg)		Model Number		Model Number		Model Number	
<b>HXD-30</b> (3290 Nm)	1700	<b>32</b>	28,5	<b>CC-332</b>	0,6	–	–	–	–	–	–	–
	2100	<b>36</b>	31,5	<b>CC-336</b>	0,7	–	–	–	–	–	–	–
	2500	<b>41</b>	34,5	<b>CC-341</b>	0,7	41/36	<b>IN3-4136</b>	41/32	<b>IN3-4132</b>	41/30	<b>IN3-4130</b>	<b>HR-41</b>
	2890	<b>46</b>	38,5	<b>CC-346</b>	0,8	46/41	<b>IN3-4641</b>	46/36	<b>IN3-4636</b>	46/32	<b>IN3-4632</b>	<b>HR-46</b>
	3290	<b>50</b>	42,0	<b>CC-350</b>	0,9	50/46	<b>IN3-5046</b>	50/41	<b>IN3-5041</b>	50/36	<b>IN3-5036</b>	<b>HR-50</b>
		<b>55</b>	45,0	<b>CC-355</b>	1,0	55/50	<b>IN3-5550</b>	55/46	<b>IN3-5546</b>	55/41	<b>IN3-5541</b>	<b>HR-55</b>
<b>HXD-60</b> (6190 Nm)	3840	<b>41</b>	34,5	<b>CC-641</b>	1,2	41/36	<b>IN6-4136</b>	–	–	–	–	<b>HR-41</b>
	4805	<b>46</b>	39,5	<b>CC-646</b>	1,3	–	–	–	–	–	–	–
	5410	<b>50</b>	43,5	<b>CC-650</b>	1,4	50/46	<b>IN6-5046</b>	50/41	<b>IN6-5041</b>	50/36	<b>IN6-5036</b>	<b>HR-50</b>
		<b>55</b>	46,5	<b>CC-655</b>	1,5	55/50	<b>IN6-5550</b>	55/46	<b>IN6-5546</b>	55/41	<b>IN6-5541</b>	<b>HR-55</b>
		<b>60</b>	48,5	<b>CC-660</b>	1,6	60/55	<b>IN6-6055</b>	60/50	<b>IN6-6050</b>	60/46	<b>IN6-6046</b>	<b>HR-60</b>
	6190	<b>65</b>	52,5	<b>CC-665</b>	1,8	65/60	<b>IN6-6560</b>	65/55	<b>IN6-6555</b>	65/50	<b>IN6-6550</b>	<b>HR-65</b>
		<b>70</b>	55,5	<b>CC-670</b>	1,9	70/65	<b>IN6-7065</b>	70/60	<b>IN6-7060</b>	70/55	<b>IN6-7055</b>	<b>HR-70</b>
		<b>75</b>	57,5	<b>CC-675</b>	2,0	75/70	<b>IN6-7570</b>	75/65	<b>IN6-7565</b>	75/60	<b>IN6-7560</b>	<b>HR-75</b>
<b>80</b>	60,5	<b>CC-680</b>	2,1	80/75	<b>IN6-8075</b>	80/70	<b>IN6-8070</b>	80/65	<b>IN6-8065</b>	<b>HR-80</b>		
<b>HXD-120</b> (12.500 Nm)	8000	<b>55</b>	46,5	<b>CC-1255</b>	2,6	55/50	<b>IN12-5550</b>	55/46	<b>IN12-5546</b>	55/41	<b>IN12-5541</b>	<b>HR-55</b>
		<b>60</b>	48,5	<b>CC-1260</b>	2,7	60/55	<b>IN12-6055</b>	60/50	<b>IN12-6050</b>	60/46	<b>IN12-6046</b>	<b>HR-60</b>
	9800	<b>65</b>	52,5	<b>CC-1265</b>	2,7	65/60	<b>IN12-6560</b>	65/55	<b>IN12-6555</b>	65/50	<b>IN12-6550</b>	<b>HR-65</b>
		<b>70</b>	55,5	<b>CC-1270</b>	2,8	70/65	<b>IN12-7065</b>	70/60	<b>IN12-7060</b>	70/55	<b>IN12-7055</b>	<b>HR-70</b>
		<b>75</b>	57,5	<b>CC-1275</b>	2,9	75/70	<b>IN12-7570</b>	75/65	<b>IN12-7565</b>	75/60	<b>IN12-7560</b>	<b>HR-75</b>
	–	–	–	–	–	–	–	–	–	–	–	–
	10.860	<b>80</b>	60,5	<b>CC-1280</b>	3,0	80/75	<b>IN12-8075</b>	80/70	<b>IN12-8070</b>	80/65	<b>IN12-8065</b>	<b>HR-80</b>
	12.500	<b>85</b>	64,5	<b>CC-1285</b>	3,5	85/80	<b>IN12-8580</b>	85/75	<b>IN12-8575</b>	85/70	<b>IN12-8570</b>	<b>HR-85</b>
		<b>90</b>	67,5	<b>CC-1290</b>	3,6	90/85	<b>IN12-9085</b>	90/80	<b>IN12-9080</b>	90/75	<b>IN12-9075</b>	<b>HR-90</b>
		<b>95</b>	70,5	<b>CC-1295</b>	3,7	95/90	<b>IN12-9590</b>	95/85	<b>IN12-9585</b>	95/80	<b>IN12-9580</b>	<b>HR-95</b>
<b>100</b>	73,5	<b>CC-12100</b>	3,8	100/95	<b>IN12-10095</b>	100/90	<b>IN12-10090</b>	100/85	<b>IN12-10085</b>	<b>HR-100</b>		
<b>HXD-240</b> (24.210 Nm)	13.890	<b>80</b>	62,0	<b>CC-2480</b>	5,1	80/75	<b>IN24-8075</b>	80/70	<b>IN24-8070</b>	80/65	<b>IN24-8065</b>	<b>HR-80</b>
	16.030	<b>85</b>	66,0	<b>CC-2485</b>	5,2	85/80	<b>IN24-8580</b>	85/75	<b>IN24-8575</b>	85/70	<b>IN24-8570</b>	<b>HR-85</b>
	16.560	<b>90</b>	69,0	<b>CC-2490</b>	5,2	90/85	<b>IN24-9085</b>	90/80	<b>IN24-9080</b>	90/75	<b>IN24-9075</b>	<b>HR-90</b>
	17.100	<b>95</b>	72,0	<b>CC-2495</b>	5,4	95/90	<b>IN24-9590</b>	95/85	<b>IN24-9585</b>	95/80	<b>IN24-9580</b>	<b>HR-95</b>
	18.170	<b>100</b>	76,0	<b>CC-24100</b>	5,6	100/95	<b>IN24-10095</b>	100/90	<b>IN24-10090</b>	100/85	<b>IN24-10085</b>	<b>HR-100</b>
	20.840	<b>105</b>	80,0	<b>CC-24105</b>	5,7	105/100	<b>IN24-105100</b>	105/95	<b>IN24-10595</b>	105/90	<b>IN24-10590</b>	<b>HR-105</b>
	24.210	<b>110</b>	84,0	<b>CC-24110</b>	5,8	110/105	<b>IN24-110105</b>	110/100	<b>IN24-110100</b>	110/95	<b>IN24-11095</b>	<b>HR-110</b>
		<b>115</b>	87,0	<b>CC-24115</b>	7,1	115/110	<b>IN24-115110</b>	115/105	<b>IN24-115105</b>	115/100	<b>IN24-115100</b>	<b>HR-115</b>
		<b>120</b>	90,0	<b>CC-24120</b>	7,3	120/115	<b>IN24-120115</b>	120/110	<b>IN24-120110</b>	120/105	<b>IN24-120105</b>	<b>HR-120</b>
		<b>125</b>	93,0	<b>CC-24125</b>	7,3	125/120	<b>IN24-125120</b>	125/115	<b>IN24-125115</b>	125/110	<b>IN24-125110</b>	<b>HR-125</b>
<b>130</b>		96,0	<b>CC-24130</b>	7,4	130/125	<b>IN24-130125</b>	130/120	<b>IN24-130120</b>	130/115	<b>IN24-130115</b>	<b>HR-130</b>	

Other Reducer Insert dimensions available upon request.

<sup>1)</sup> See the table of hexagon bolt and nut sizes and related thread diameters on page 82.

▼ PTW1000



## Productivity

- High speed continuous rotation for constant torque output
- Low friction planetary gearbox design minimizes wear and extends uptime

## Safety

- Ergonomic, low vibration design reduces fatigue and the risk of vibration related injuries for the operator
- Low noise air motor provides quiet, consistent performance for indoor and outdoor applications

## Convenience

- Provided with standard reaction arm; wide assortment of custom arms and accessories are available
- Available with or without Filter-Regulator-Lubricator (FRL)
- Unique calibration certificate provided with each tool.



◀ The PTW1000 makes quick work of this flange maintenance job.

## Continuous Rotation Controlled Torque



### Calibration Certificate

All PTW-Series tools are CE declared and are shipped complete with a calibration certificate.



### Typical Pneumatic Torque Wrench Applications

#### Oil and Gas, MRO

- Pipe flanges
- Valves
- Man-way covers
- Pressure vessels

#### Power Generation

- Turbine bolts
- Tower segments
- Turbine casings

#### Mining

- Track maintenance
- Undercarriage maintenance
- Wheel maintenance
- Shovel maintenance.

▼ PTW-Series Pneumatic Torque Wrenches are ideal for applications where speed and precision are critical, such as track maintenance.



# Pneumatic Torque Wrenches



## PTW-Series, Pneumatic Torque Wrenches

Enerpac PTW-Series Pneumatic Torque Wrenches are designed for applications that require speed and control.

The standard package includes a Torque Wrench with a calibration certificate, an FRL (Filter/Regulator/Lubricator), and a 3 m long, 1/2" inch (13 mm) diameter air hose, which connects the FRL to the wrench.

Once the air hoses are connected, the operator simply adjusts the air pressure on

the FRL to achieve the desired torque using the calibration certificate. After this, the tool is ready to go to work! \*

The air source used with the PTW system must be regulated and/or limited to 8,3 bar, and must be capable of providing a volume of at least (85 m<sup>3</sup>/h) at 6,9 bar. A separate 1/2" inch hose (not included) must be used to connect the FRL to the air supply.

\* See instruction manual for comprehensive instructions.

## PTW Series



Maximum Torque Output:

**8135 Nm**

Square Drive Range:

**1 - 1 1/2 inch**



### Accessories

Enerpac offers a full line of accessories including a range of reaction arms and drives.

Page: **38**



### FRL120C, Filter-Regulator-Lubricator with air hose

All PTW-Series tools are shipped complete with standard reaction arm, and Filter-Regulator-Lubricator (FRL120C).



### BSH-Series Sockets

Heavy-Duty Impact Sockets for power driven torquing equipment.

Page: **10**



### Hydraulic Torque Wrenches

Enerpac offers a complete range of square drive and hexagon cassette torque wrenches.

Page: **1**

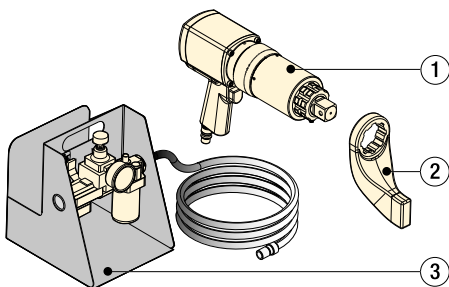

- ① PTW Torque Wrench
- ② Standard Reaction Arm
- ③ FRL120C Filter-Regulator-Lubricator with 3 meters air hose

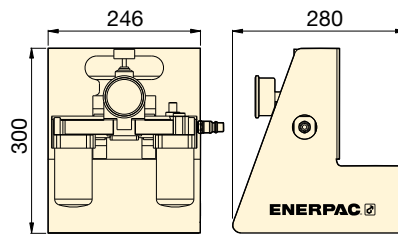
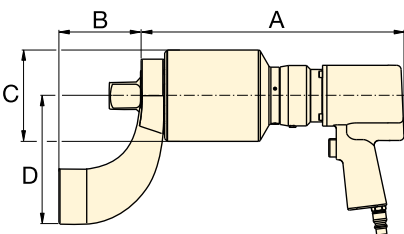

### ▼ SELECTION CHART

All tools are shipped complete with standard reaction arm and FRL120C.

Minimum Torque		Maximum Torque		Square Drive (inch)	Model Number <sup>1)</sup> (FRL120C included)	Speed (RPM)	Dimensions (mm)				Weight (kg) <sup>2)</sup>
(Nm)	(Ft.lbs)	(Nm)	(Ft.lbs)				A	B	C	D	
407	300	1356	1000	1	<b>PTW1000C</b>	12,6	272	83	72	130	8,2
678	500	2712	2000	1	<b>PTW2000C</b>	8,0	286	83	79	133	8,8
1220	900	4067	3000	1	<b>PTW3000C</b>	3,1	343	83	95	133	10,4
1763	1300	8135	6000	1 1/2	<b>PTW6000C</b>	2,5	366	114	127	178	17,7

<sup>1)</sup> To order without FRL120C, remove "C" suffix from model number (example: **PTW3000**).

<sup>2)</sup> Weight does not include reaction arm. Reaction arm weight for PTW1000, PTW2000, PTW3000 is 1,3 kg and for PTW6000 is 3,5 kg.

▼ ETW3000E (wrench shown only; wrench cannot be purchased or used without control box)



## Performance

- High speed continuous rotation gets the job done faster
- Torque and angle functionality allows input of nominal torque value followed by a specific angle of rotation
- Pass/Fail LED indicator on back of tool verifies fastening has been completed according to specified input.

## Simplicity

- Control box with 7-inch touchscreen simplifies tool operation
- Controls on back of wrench enable operator to monitor and manage the fastening process without returning to the control box
- Brightly lit three line LED display on wrench is easy to read in any environment, even in bright sunlight.

## Traceability

- Fastening record can be viewed on-screen and transferred through standard USB connection on the control box
- Each tool is performance tested and shipped complete with a factory calibration certificate.

## Safety

- Lift points on wrench enable use with positioning handle or lifting device for greater handling safety
- Ground fault detector protects operator in the event of insufficient grounding.

## Your Simple Solution for Smart Bolting



### Touchscreen Control Box

ETW-Series tools feature an easy to use, interactive touch-screen control box, which helps make even the most complex jobs simple to complete.



### Easy Access to Controls

Controls on back of wrench with LED display allow user to directly input desired torque, change direction of rotation, and monitor the fastening process.



### Certifications and Declarations

All ETW-Series tools:

- Are CE declared
- Are shipped complete with a calibration certificate
- Are certified for North American Electrical Safety by CSA International
- Carry a CSA US and Canada mark.



▼ ETW-Series Electric Torque Wrenches are ideal for high volume fastening applications that require precision and traceability, such as this wind tower job.





## ETW-Series, Electric Torque Wrenches

Enerpac ETW-Series Electric Torque Wrenches are particularly well suited to complex jobs which demand precision and traceability.

The ETW-Series tools feature an automatic mode, which helps simplify and automate complex jobs, including those with torque and angle specifications, through the creation of presets.

Using the touchscreen, simply input the number of fasteners and desired torque value for each fastening step, followed by the required angle of turn. This sequence may then be saved as an automatic preset for future use.

For simpler jobs, torque values may be input with a digital slider on the touchscreen, or directly into the rear control panel of the wrench.

Once the input torque is achieved, the tool stalls, and a pass/fail indicator verifies that it is ready to move on to the next fastener.

When the job is completed, the fastening record can be viewed on the touch screen, or exported to a computer via a USB connection on the control box.

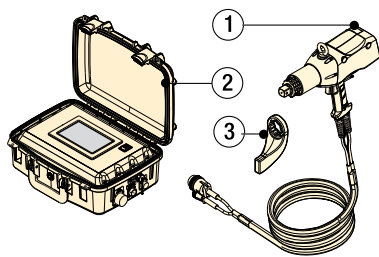

- ① ETW Torque Wrench
- ② Control Box
- ③ Standard Reaction Arm

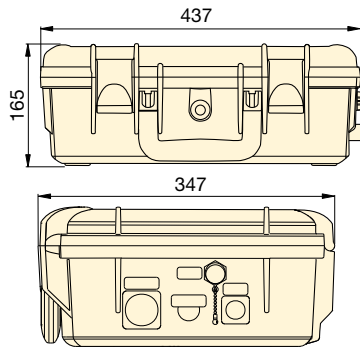
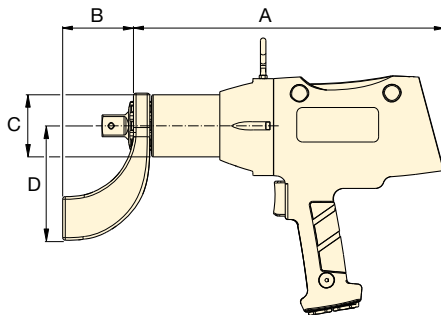

## ETW Series



Maximum Torque Output:

**8135 Nm**

Square Drive Range:

**1 - 1½ inch**



### Accessories

Enerpac offers a full line of accessories including a range of reaction arms and drives.

Page: **38**



### BSH-Series Sockets

Heavy-Duty Impact Sockets for power driven torquing equipment.

Page: **10**

**Voltage: (Model Number ending with suffix)**

**B** = 115V, 60 Hz

**I** = 230V, 60 Hz (with NEMA 6-15 plug)

**E** = 230V, 50 Hz (with commonly used European (SCHUKO) plug)

Minimum Torque		Maximum Torque		Square Drive (inch)	Model Number	Voltage	Speed (RPM)	Dimensions (mm)				Weight (kg) <sup>1)</sup>
(Nm)	(Ft.lbs)	(Nm)	(Ft.lbs)					A	B	C	D	
270	200	1355	1000	1	<b>ETW1000B</b>	115V 60 Hz	9,8	365	83	72	130	8,2
270	200	1355	1000	1	<b>ETW1000I</b>	230V 60 Hz	15,2	365	83	72	130	8,2
270	200	1355	1000	1	<b>ETW1000E</b>	230V 50 Hz	15,2	365	83	72	130	8,2
540	400	2710	2000	1	<b>ETW2000B</b>	115V 60 Hz	5,8	380	83	79	133	8,9
540	400	2710	2000	1	<b>ETW2000I</b>	230V 60 Hz	9,0	380	83	79	133	8,9
540	400	2710	2000	1	<b>ETW2000E</b>	230V 50 Hz	9,0	380	83	79	133	8,9
810	600	4065	3000	1	<b>ETW3000B</b>	115V 60 Hz	2,8	436	83	95	133	11,9
810	600	4065	3000	1	<b>ETW3000I</b>	230V 60 Hz	4,3	436	83	95	133	11,9
810	600	4065	3000	1	<b>ETW3000E</b>	230V 50 Hz	4,3	436	83	95	133	11,9
1625	1200	8135	6000	1½	<b>ETW6000B</b>	115V 60 Hz	1,9	453	114	127	178	19,1
1625	1200	8135	6000	1½	<b>ETW6000I</b>	230V 60 Hz	2,9	453	114	127	178	19,1
1625	1200	8135	6000	1½	<b>ETW6000E</b>	230V 50 Hz	2,9	453	114	127	178	19,1

<sup>1)</sup> Weight does not include reaction arm. Standard reaction arm weight for ETW1000, ETW2000, ETW3000 is 1,3 kg and for ETW6000 is 3,5 kg. Weight of the control box is 9 kg.

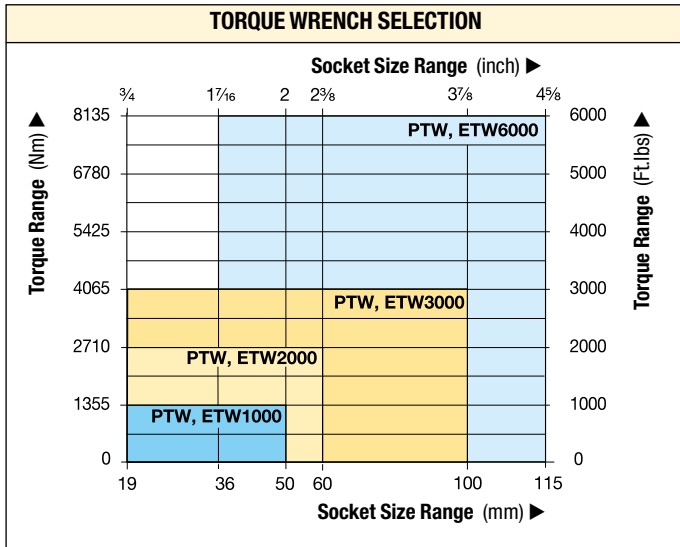

## PTW, ETW Series



Maximum Torque Output:

**8135 Nm**

Square Drive Range:

**1 - 1 1/2 inch**

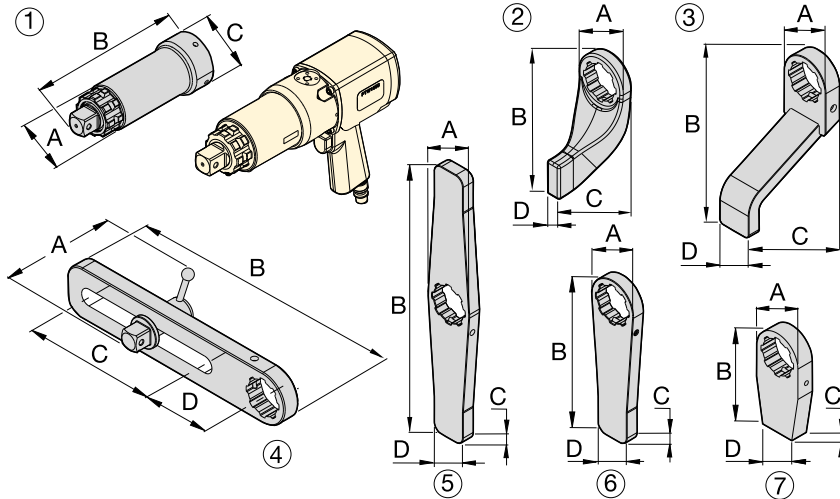

### BSH-Series Sockets

Heavy-Duty Impact Sockets for power driven torquing equipment.

Page: **10**

### Optional Accessories

#### For use with PTW and ETW1000, 2000, 3000-models

Nr.	Description	Model Nr.	Application	Dimensions (mm)			
				A	B	C	D
1	Extended Drive, 6 inch (152 mm)	ED6TWS	Nose extension, primarily for truck wheel bolts	62	206	73	-
1	Extended Drive, 12 inch (305 mm)	ED12TWS	Nose extension, primarily for truck wheel bolts	62	384	73	-
1	Extended Drive, 18 inch (457 mm)	ED18TWS	Nose extension, primarily for truck wheel bolts	62	511	73	-
2	Standard Reaction Arm	RATWS	Standard arm included with PTW and ETW model	76	172	102	21
3	Extended Reaction Arm	ERATWS	Long plate for use with deep well sockets	73	150	202	51
4	Sliding Reaction Arm	SLRATWS	For widely spaced and uneven bolt centers	112	381	203	102
5	Double Straight Reaction Arm	DSATWS	Reduces time to reposition arm *	73	406	19	102
6	Straight Reaction Arm	SRATWS	Long plate for wide spaced reaction points	73	240	19	51
7	Blank Reaction Arm **	BLTWS	Weldable blank for custom applications **	72	151	25	51

#### For use with PTW and ETW6000-models

1	Extended Drive 6 inch (152 mm)	ED6TWL	Nose extension, primarily for truck wheel bolts	84	232	102	-
1	Extended Drive 12 inch (305 mm)	ED12TWL	Nose extension, primarily for truck wheel bolts	84	384	102	-
2	Standard Reaction Arm	RATWL	Standard arm included with PTW and ETW model	102	229	146	32
3	Extended Reaction Arm	ERATWL	Long plate for use with deep well sockets	102	254	184	64
4	Sliding Reaction Arm	SLRATWL	For widely spaced and uneven bolt centers	152	419	190	114
5	Double Straight Arm	DSATWL	Reduces time to reposition arm *	102	508	32	57
6	Straight Reaction Arm	SRATWL	Long plate for wide spaced reaction points	102	305	32	57
7	Blank Reaction Arm **	BLTWL	Weldable blank for custom applications **	102	152	32	57

\* Time to reposition arm when repeatedly moving from tightening to loosening.

\*\* WARNING: Blank reaction arms must be heat treated to HRc 38-42 prior to use.



# Typical PTW and ETW-Series Torque Wrench Applications

## Mining

- Track maintenance
- Undercarriage maintenance
- Wheel maintenance
- Shovel maintenance



## Power Generation

- Turbine bolts
- Tower segments
- Turbine casings























## Oil & Gas

- Pipe flanges
- Valves
- Manway covers
- Pressure vessels



## Optimum Torque Wrench and Pump Combinations

For optimum speed and performance Enerpac recommends the following system set-up with wrench-pump-hose combinations. For other combinations, consult your Enerpac bolting expert or your authorized Enerpac distributor.

		ELECTRIC PUMPS				AIR DRIVEN PUMPS		
		PME, PMU-Series	ZU4-Series	TQ-Series	ZE-Series	PTA-Series	ZA4-Series	
								
		Page: 41	Page: 42	Page: 48	Page: 46	Page: 50	Page: 52	
<b>Speed:</b>								
<b>Reservoir Capacity:</b>	1,9 - 3,8 litres	4,0 - 8,0 litres	4,0 litres	4,0 - 40 litres	3,8 litres	4,0 - 8,0 litres		
<b>Duty Cycle:</b>	Standard	Standard	Medium	Heavy-Duty	Standard	Heavy-Duty		
<b>Weight:</b>								
<b>Field/Factory Work:</b>	Field	Field	Field/Factory	Factory	Field	Field		
<b>S-Series</b> 	S1500X	Optimal	Optimal	Optimal	Optimal	Optimal	Optimal	
	S3000X							
	S6000X							
	S11000X	-		Acceptable		-		
	S25000X							
<b>W-Series</b> 	W2000X	Optimal		Optimal		Optimal		
	W4000X			Optimal				
	W8000X							
	W15000X							
	W22000X			Acceptable				
W35000X								
<b>SQD-Series</b> 	SQD-25-I	Optimal	Optimal	-	-	Optimal	Optimal	
	SQD-50-I							
	SQD-75-I							
	SQD-100-I	-						
	SQD-160-I							
SQD-270-I								
<b>HXD-Series</b> 	HXD-30	Optimal				Optimal		
	HXD-60							
	HXD-120							
	HXD-240							
	-							



### ZU4 – Electric Wrench Pumps

Utilizing a universal motor, the ZU4-Series has excellent low voltage characteristics. It works well with long extension cords or generator driven electrical power supplies. A field proven, efficient design ensures this pump is dependable and will draw less current – lowering your operating cost. ZU4-pumps are available in Pro and Classic formats.

**ZU4 Pro pumps** have an LCD feature to display torque or pressure, selectable torque wrench, and self-diagnostics – premium features not available on any other pump.

**ZU4 Classic pumps** feature an analogue gauge and a basic electrical package to deliver durable, safe and efficient hydraulic power.

### ZE-Series Electric Wrench Pumps

The ZE-Series features premium options, such as the LCD to display torque or pressure values, and self-diagnostics. These pumps utilize an induction motor, making the ZE-Series the coolest and quietest pumps in their class.

### ZA-Series Air Driven Wrench Pumps

Utilizing the highly efficient design of the Z-Class pumping element, this air driven pump is best suited to power medium to large size torque wrenches.

### TQ-700 Series Electric Wrench Pumps

Designed for both portability and production, the TQ-700 features optimized flow technology to deliver superior bolting speed.



### Torque Wrench Hoses

Use Enerpac twin safety hoses to connect your torque wrench to the pump.

For S & W	Modelnr.
6 m long, 2 hoses	THQ-706T
12 m long, 2 hoses	THQ-712T
For SQD & HXD	
6 m long, 2 hoses	THC-7062
12 m long, 2 hoses	THC-7122

# Portable Electric Torque Wrench Pumps

▼ Shown: PMU-10422



- Powerful two-speed pump is lightweight and easy to carry
- Standard heat exchanger package on PMU-Series keeps pump cool under extreme use
- Glycerin filled gauge with scales reading in psi and bar
- Transparent overlays in Nm and Ft.lbs for all Enerpac torque wrenches provide a quick torque reference
- Universal motor for a high power-to-weight ratio; generates full pressure on as little as 50% of the rated line voltage
- Adjustable pressure relief valve for accurate torque adjustments and precise repeatability.

## ▼ SELECTION CHART

For Use with Torque Wrenches		Maximum Pressure Rating (bar)		Oil Flow Rate (l/min)		Model Number with Heat Exchanger *	Useable Oil Capacity (litres)	Electric Motor (Volt-phase-Hz)	Dimensions L x W x H (mm)	Weight (kg)
		1 <sup>st</sup> stage	2 <sup>nd</sup> stage	1 <sup>st</sup> stage	2 <sup>nd</sup> stage					
S1500X S3000X	W2000X W4000X	48	700	3,3	0,33	PMU-10427-Q	1,9	115 - 1 - 50/60	431x280x381	21
		48	700	3,3	0,33	PMU-10447-Q	3,8	115 - 1 - 50/60	431x330x381	24
		48	700	3,3	0,33	PMU-10422-Q	1,9	230 - 1 - 50/60	431x280x381	21
		48	700	3,3	0,33	PMU-10442-Q	3,8	230 - 1 - 50/60	431x330x381	24
SQD-25-I SQD-50-I	HXD-30 HXD-60	48	800	3,3	0,33	PMU-10427	1,9	115 - 1 - 50/60	431x280x381	21
		48	800	3,3	0,33	PMU-10447	3,8	115 - 1 - 50/60	431x330x381	24
		48	800	3,3	0,33	PMU-10422	1,9	230 - 1 - 50/60	431x280x381	21
		48	800	3,3	0,33	PMU-10442	3,8	230 - 1 - 50/60	431x330x381	24

\* For pump without heat exchanger change PMU into PME. Example **PME-10442-Q**.  
PME-Series pump size: 250 x 250 x 360 mm. Weight 18 kg (1,9 litres) and 21 kg (3,8 litres).

## PME PMU Series



Reservoir Capacity:  
**1,9 - 3,8 litres**

Flow at Rated Pressure:  
**0,33 l/min**

Motor Size:  
**0,37 kW**

Maximum Operating Pressure:  
**700 - 800 bar**



### Torque Wrench Hoses

Use Enerpac twin safety hoses to connect your torque wrench to the pump.

For 700 bar	Model-Nr.
6 m long, 2 hoses	THQ-706T
12 m long, 2 hoses	THQ-712T
For 800 bar	
6 m long, 2 hoses	THC-7062
12 m long, 2 hoses	THC-7122



### Gauge and Overlay Kit

Available separately for use with PME, PMU-Series pumps:  
**GT-4015Q** includes gauge and overlays for all S- and W-Series wrenches. **GT-4015** includes gauge and overlays for all SQD and HXD-Series wrenches.

▼ ZU4204TE-Q (Pro Electric serie), ZU4204BE-Q (Classic Electric serie)



## Z Tough, Dependable Innovative CLASS



### Classic Electrical

Basic electrical package includes mechanical contactor, ON/OFF toggle switch, pendant with electro-mechanical push buttons, 24V transformer timer and operator accessible circuit breaker.

- Features Z-Class high-efficiency pump design; higher oil flow and bypass pressure, cooler running and requires 18% less current draw than comparable pumps
- Powerful 1,25 kW universal electric motor provides high power-to-weight ratio and excellent low-voltage operating characteristics
- High-strength, molded composite shroud protects motor and electrical components, while providing an ergonomic, non-conductive handle for easy transport
- Pendant provides additional safety for the operator.

### Pro Series pumps only

- LCD readout provides pressure display and a number of diagnostic and readout capabilities never before offered on a portable electric pump
- Auto-Cycle feature provides continuous cycle operation of the torque wrench as long as the advance button is pressed (pump can be used with or without auto cycle).



### Pro-Series Pump Models

Back-lit LCD and Pressure Transducer featuring Auto-Cycle Technology.

- Digital read-out and "Autocycle" setting
- Display pressure (bar, MPa, psi) or torque (Nm, Ft.lbs) read-out
- Torque wrench model is selectable
- Pump usage information, hour and cycle counts
- Low-voltage warning and recording
- Self-test and diagnostic capabilities
- Information can be displayed in English, French, German, Italian, Spanish and Portuguese
- Pressure transducer is more accurate and durable than analog gauges
- Easy-viewing variable rate display.



◀ Any brand of hydraulic torque wrench can be powered by the portable ZU4T-Series torque wrench pump.

# ZU4T-Series, Torque Wrench Pumps



## Z-Class – A Pump For Every Application

Patented Z-Class pump technology provides high by-pass pressures for increased productivity – important in applications using long hose runs and high pressure-drop circuits, like heavy lifting or certain double-acting tools. Enerpac ZU4T-Series pumps are built to power small to large torque wrenches. Choosing the right ZU4T-Series torque wrench pump for your application is easy.

### Classic Electric Torque Wrench Pumps

- The Classic has traditional electro-mechanical components (transformers, relays and switches) in place of solid-state electronics. The Classic delivers durable, safe and efficient hydraulic power.

### Pro Series Electric Torque Wrench Pump

- Digital (LCD) display features a built-in hour meter, pressure display and shows self-diagnostic, cycle-count and low voltage warning information. These premium features are not available on any other pump – anywhere!
- Auto-Cycle feature provides continuous cycle operation of the torque wrench as long as the advance button is pressed (pump can be used with or without Auto-Cycle feature).

## ZU4T Series



Reservoir Capacity:

**4,0 - 8,0 litres**

Flow at Rated Pressure:

**1,0 l/min**

Motor Size:

**1,25 kW**

Maximum Operating Pressure:

**700 - 800 bar**



### Torque Wrench Pump Selection

For optimum speed and performance see the torque wrench pump and hose selection matrix.

Page: **40**

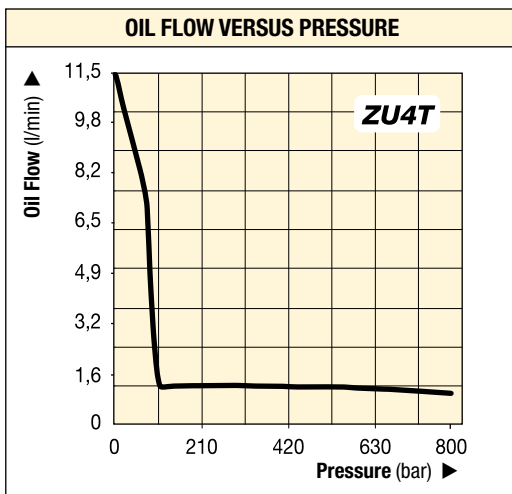

### COMMON PUMP MODELS

For Use With Torque Wrenches	Model Number <sup>1) 4)</sup>	Motor Electrical Specification	Usable Oil Capacity (litres)	(kg)
Pro Series pumps All wrenches	ZU4204TB-Q	115 VAC, 1-ph	4,0	32
	ZU4208TB-Q	115 VAC, 1-ph	8,0	34
	ZU4204TE-Q <sup>2)</sup>	208-240 VAC, 1-ph	4,0	32
	ZU4208TE-Q <sup>2)</sup>	208-240 VAC, 1-ph	8,0	34
	ZU4204TI-Q <sup>3)</sup>	208-240 VAC, 1-ph	4,0	32
	ZU4208TI-Q <sup>3)</sup>	208-240 VAC, 1-ph	8,0	34
Classic pumps All wrenches	ZU4204BB-QH	115 VAC, 1-ph	4,0	37
	ZU4204BB-Q	115 VAC, 1-ph	4,0	33
	ZU4208BE-QH <sup>2)</sup>	208-240 VAC, 1-ph	8,0	38
	ZU4204BE-Q <sup>2)</sup>	208-240 VAC, 1-ph	4,0	34
	ZU4208BI-QH <sup>3)</sup>	208-240 VAC, 1-ph	8,0	40
	ZU4208BI-Q <sup>3)</sup>	208-240 VAC, 1-ph	8,0	36



### Pump Ratings

-Q suffix pumps are for **700 bar** torque wrenches, and include spin-on couplers.

-E suffix pumps are for use with Enerpac SQD and HXD-Series **800 bar** torque wrenches, and include polarized lock-ring safety couplers.

Page: **44**



### Gauge and Overlay Kit

Available separately for use with ZU4T-Series Classic:

**GT-4015Q** includes gauge and overlays for all S- and W-Series

torque wrenches.

**GT-4015** includes gauge and overlays for all SQD and HXD torque wrenches.

<sup>1)</sup> All models meet CE safety requirements and all CSA requirements.

<sup>2)</sup> European plug and CE EMC directive compliant

<sup>3)</sup> With NEMA 6-15 plug

<sup>4)</sup> Select -E suffixed pumps for Enerpac SQD and HXD-Series 800 bar torque wrenches, see page 44.

# ZU4T-Series, Ordering Matrix & Specifications

▼ This is how a ZU4T-Series pump model number is built up:

<b>Z</b>	<b>U</b>	<b>4</b>	<b>2</b>	<b>08</b>	<b>T</b>	<b>E</b>	<b>-</b>	<b>Q</b>	<b>H</b>	<b>M</b>
1 Product Type	2 Motor Type	3 Flow Group	4 Valve Type	5 Reservoir Size	6 Valve Operation	7 Voltage	8 Must be E or Q	8 Options	8 Options	8 Options

### 1 Product Type

**Z** = Pump series

### 2 Motor Type

**U** = Universal electric motor

### 3 Flow Group

**4** = 1,0 l/min @ 700 bar

### 4 Valve Type

**2** = Torque wrench valve

### 5 Reservoir Size

**04** = 4,0 litres usable oil

**08** = 8,0 litres usable oil

### 6 Valve Operation

**T** = Pro Electric Serie pump with solenoid valve and pendant, LCD Electric and pressur transducer

**B** = Classic Electric pump with solenoid valve and pendant.

### 7 Voltage

**B** = 115V, 1 ph, 50/60 Hz

**E** = 208-240V, 1 ph, 50/60 Hz (with European plug CE RF compliant)

**I** = 208-240V, 1 ph, 50/60 Hz (with NEMA 6-15 plug)

### 8 Options

**E** = with 800 bar coupler for use with HXD and SQD-Series or other wrenches

**Q** = with 700 bar coupler for use with S and W-Series or other wrenches

**H** = Heat exchanger

**K** = Skid bar

**M** = 4-wrench manifold

**R** = Roll cage



### How to order your ZU4T-Series torque wrench pump

Ordering Example

Model No. **ZU4208TE-QMHM**

**700 bar Pro Electric Series** pump for use with Enerpac S and W-Series and other 700 bar torque wrenches, 230V motor, 8 litres reservoir, 4-wrench manifold, heat exchanger and skidbar.

Refer to the torque wrench pump selection matrix for optimum wrench, pump and hose combinations.

Page: **40**

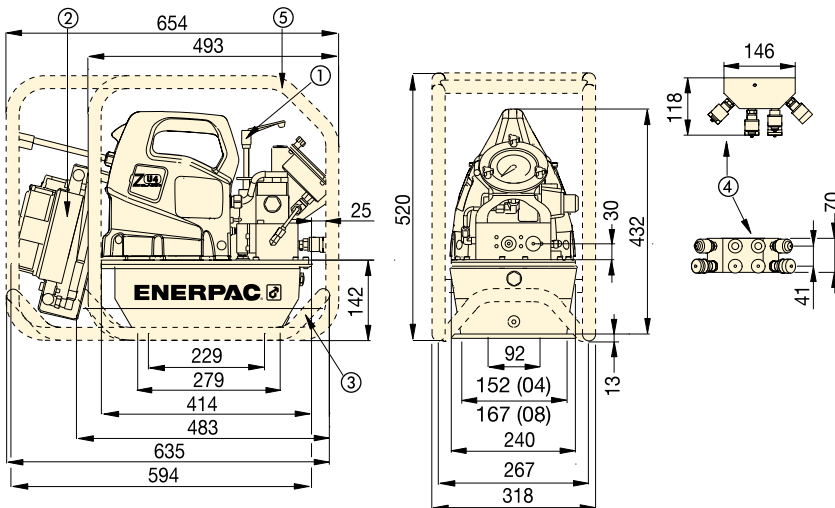

### ZU4T-Series Torque Wrench Pumps

- ① User adjustable relief valve
- ② Heat Exchanger (optional)
- ③ Skidbar (optional)
- ④ 4-wrench manifold (optional)
- ⑤ Roll cage (optional)



### Torque Wrench Hoses

Use Enerpac twin safety hoses to connect your torque wrench to the pump.

For 700 bar	Model Nr.
6 m long, 2 hoses	<b>THQ-706T</b>
12 m long, 2 hoses	<b>THQ-712T</b>
For 800 bar	
6 m long, 2 hoses	<b>THC-7062</b>
12 m long, 2 hoses	<b>THC-7122</b>

### ZU4T-Series Performance Chart

Motor Size (kW)	Output Flow Rate (l/min)				Motor Electrical Specification (Volt - Phase - Hz)	Sound Level (dBA)	Relief Valve Adjustment Range (bar)
	7 bar	50 bar	350 bar	700 bar			
1,25	11,5	8,8	1,2	1,0	115 - 1 - 50/60 208-240 - 1 - 50/60	85-90	124-700 *

\* Pump type (-Q) shown, (-E) range is 124-800 bar.

# ZU4T-Series, Pump Options



## Heat Exchanger

- Removes heat from the bypass oil to provide cooler operation
- Stabilizes oil viscosity, increasing oil life and reduces wear of pump and other hydraulic components.

Accessory Kit * Model Nr.	Can be used on ZU4-Series torque wrench pumps
<b>ZHE-U115</b>	115 Volt pumps
<b>ZHE-U230</b>	230 Volt pumps

\* Add suffix **H** to pump model number for factory installation.

Heat Exchanger adds 4,1 kg to pump weight.

Ordering Example: **ZU4208TE-QH**



## Skid Bar

- Provides greater pump stability on soft or uneven surfaces
- Provides easy two-handed lift.

Accessory Kit * Model Nr.	Can be used on ZU4-Series torque wrench pumps
<b>SBZ-4</b>	04 and 08 reservoir <sup>1)</sup>
<b>SBZ-4L</b>	04 and 08 reservoir <sup>2)</sup>

\* Add suffix **K** to pump model number for factory installation.

<sup>1)</sup> For pump without heat exchanger 2,2 kg.

<sup>2)</sup> For pump with heat exchanger 3,2 kg.

Ordering Example: **ZU4208TE-QK**



## Roll Cage

- Protects pump
- Provides greater pump stability.

Accessory Kit * Model Nr.	Can be used on ZU4-Series torque wrench pumps
<b>ZRC-04</b>	04 and 08 reservoir <sup>1)</sup>
<b>ZRC-04H</b>	04 and 08 reservoir <sup>2)</sup>

\* Add suffix **R** for factory installation.

<sup>1)</sup> For pump without heat exchanger 5 kg.

<sup>2)</sup> For pump with heat exchanger 7 kg.

Ordering Example: **ZU4208TE-QR**



## 4-Wrench Manifold

- For simultaneous operation of multiple torque wrenches
- Can be factory installed or ordered separately.

Accessory Kit * Model Nr.	Can be used on ZU4-Series torque wrench pumps
<b>ZTM-E</b>	for 800 bar torque wrenches
<b>ZTM-Q</b>	for 700 bar torque wrenches

\* Add suffix **M** for factory installation.

Weight 4,0 kg.

Ordering Example: **ZU4208TE-QM**

## ZU4T Series



Reservoir Capacity:

**4,0 - 8,0 litres**

Flow at Rated Pressure:

**1,0 l/min**

Motor Size:

**1,25 kW**

Maximum Operating Pressure:

**700 - 800 bar**

▼ Most hydraulic torque wrenches can be powered by the Enerpac ZU4T-Series torque wrench pump.



# ZE-Series, Electric Torque Wrench Pumps

**ENERPAC**   
POWERFUL SOLUTIONS. GLOBAL FORCE.

▼ ZE4204TE-QHR



**Z** Tough,  
Dependable  
Innovative  
**CLASS**

- **Auto-Cycle** feature provides continuous cycle operation of the torque wrench as long as the advance button is pressed (pump can be used with or without auto cycle feature)
- **LCD readout** provides pressure and torque display and a number of diagnostic and readout capabilities never before offered on a portable electric pump
- **Totally enclosed, fan-cooled industrial electric motors** supply extended life and stand up to harsh industrial environments
- **High-strength, molded electrical enclosure** protects electronics, power supplies and LCD readout from harsh environments.



**Back-lit LCD and Pressure Transducer** featuring **Auto-Cycle Technology**

- Digital read-out and "Autocycle" setting
- Display pressure (bar, MPa, psi) or torque (Nm, Ft.lbs) read-out
- Torque wrench model is selectable
- Pump usage information, hour and cycle counts
- Low-voltage warning and recording
- Self-test and diagnostic capabilities
- Information can be displayed in English, French, German, Italian, Spanish and Portuguese
- Pressure transducer is more accurate and durable than analog gauges
- Easy-viewing variable rate display.



◀ *The ZE-Series torque wrench pumps are perfectly matched for this W2000X wrench.*



# ZE-Series, Electric Torque Wrench Pumps

ZE-SERIES OIL FLOW VERSUS PRESSURE

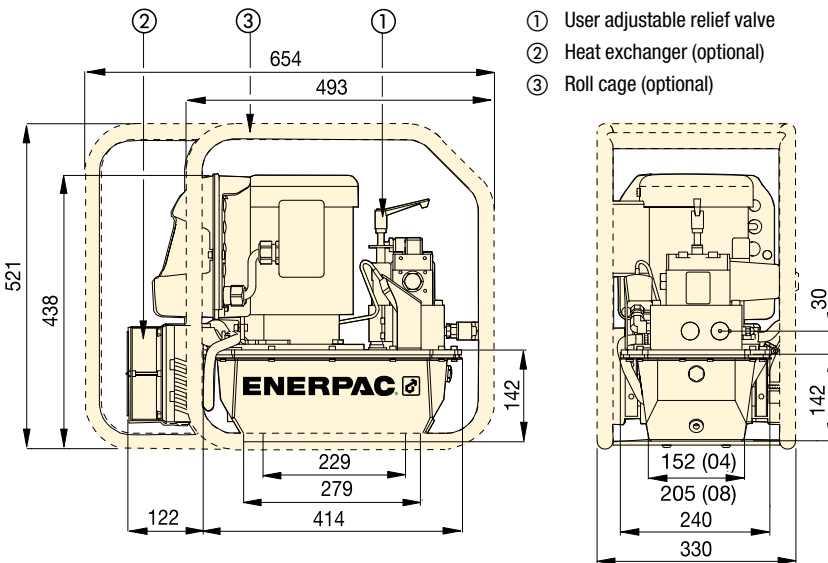
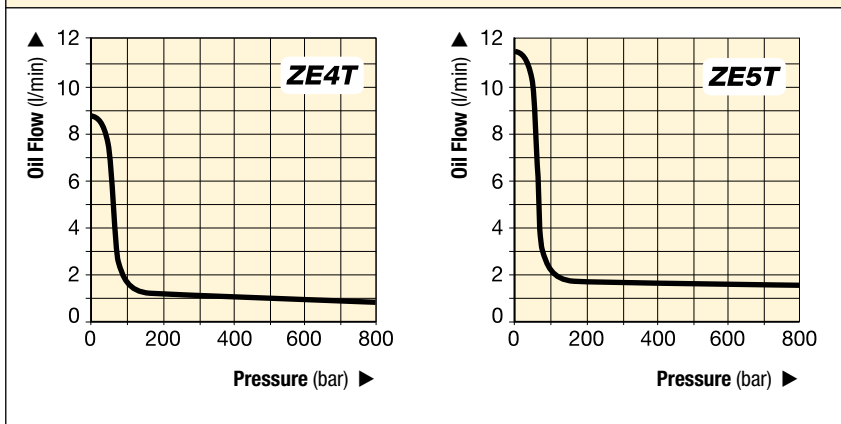

ZE-Series, 4 and 8 litres reservoirs

▼ COMMON TORQUE WRENCH PUMP MODELS

For Use With Torque Wrenches	Maximum Operating Pressure (bar)	Model Number with Heat Exchanger and Roll Cage	Motor Electrical Specification (Volt - Ph - Hz)	Usable Oil Capacity <sup>1)</sup> (litres)	Weight (kg)
all S and W-Series	700	ZE4204TB-QHR	115 - 1 - 50/60	4,0	61
	700	ZE4204TE-QHR	230 - 1 - 50/60	4,0	61
	700	ZE4204TG-QHR	230 - 3 - 50/60	4,0	62
	700	ZE5204TW-QHR	400 - 3 - 50/60	4,0	62
all SQD and HXD-Series	800	ZE4204TB-EHR	115 - 1 - 50/60	4,0	61
	800	ZE4204TE-EHR	230 - 1 - 50/60	4,0	61
	800	ZE4204TG-EHR	230 - 3 - 50/60	4,0	62
	800	ZE5204TW-EHR	400 - 3 - 50/60	4,0	62

<sup>1)</sup> Larger reservoirs (8, 10, 20 and 40 litres) are available. Contact Enerpac.

▼ PERFORMANCE CHART

Pump Series	Output Flow Rate at 50 Hz <sup>2)</sup> (l/min)				Motor Size (kW)	Relief Valve Adjustment Range (bar)	Sound Level (dBA)
	7 bar	50 bar	350 bar	700 bar			
ZE4T	8,8	8,1	0,9	0,8	1,1	70 - 800	75
ZE5T	11,8	11,2	1,7	1,6	2,2	70 - 800	75

<sup>2)</sup> Flow rate will be approximately 6/5 higher at 60 Hz.

**ZE Series**



Reservoir Capacity:  
**4,0 - 40 litres**

Flow at Rated Pressure:  
**0,82 - 1,64 l/min**

Motor Size:  
**1,1 - 2,2 kW**

Maximum Operating Pressure:  
**700 - 800 bar**



**Torque Wrench Pump Selection**

For optimum speed and performance see the torque wrench pump and hose selection matrix.

Page: **40**



**Torque Wrench Hoses**

Use Enerpac twin safety hoses to connect your torque wrench to the pump.

For 700 bar	Model Nr.
6 m long, 2 hoses	THQ-706T
12 m long, 2 hoses	THQ-712T
For 800 bar	
6 m long, 2 hoses	THC-7062
12 m long, 2 hoses	THC-7122



**4-Wrench Manifold**

For simultaneous operation of multiple torque wrenches.

4-Wrench Manifold	Model Nr.
for 700 bar torque wrenches	ZTM-Q
for 800 bar torque wrenches	ZTM-E

▼ TQ-700E



- **Optimized flow technology – three stage pump maximizes productivity of the pump and tool while minimizing heat build-up and down time**
- **Heat exchanger is standard included**
- **A quiet (<85 dBA), lightweight pump with a compact footprint – easy to move around and through the work site**
- **Durable roll cage with an ergonomically sized handle and shielded gauge – a pump that is easy to put into position and safe from on site operational hazards**
- **Maintenance made simple with a brushless motor designed for continuous usage**
- **Straightforward operation with a simple pressure set and convenient to use 6 m pendant control – immediate productivity for crews operating the pump**
- **IP55 Rating for superior dust and water protection**
- **Transparent gauge overlays in Nm and Ft.lbs for all Enerpac S and W-Series torque wrenches provide a quick torque reference.**

## Lightweight Torque Wrench Pumps



### Four Port Manifold

The TQ-700E offers an optional four wrench manifold as an accessory factory installed. (Add suffix "M" at the end of the model number. For example: **TQ-700EM**).



### Hydraulic Torque Wrenches

Enerpac offers a complete range of square drive and hexagon cassette torque wrenches.

Page:  1



### Torque Wrench Hoses

Use Enerpac THQ-700 series twin hoses with 700 bar pumps.

For 700 bar	Model Nr.
6 meters long, 2 hoses	<b>THQ-706T</b>
12 meters long, 2 hoses	<b>THQ-712T</b>

*The TQ-700E and the W-Series wrenches are a productive combination in wind power applications. ►*



# Electric Torque Wrench Pumps



## TQ-700 Applications

The TQ-Series pump is ideal for powering hydraulic wrenches for the Power Generation and Wind Markets. The TQ-700 has been engineered with Optimized Flow Technology to deliver up to 50% faster bolt tightening than competing pumps.

Bolting speed is more complex than how much oil flow per minute the pump produces. The key is optimizing the flow rate across the entire bolting cycle. With more oil flowing at the right time and at the right volume, you achieve the optimized flow for a hydraulic bolting system. The result of this optimized flow is more bolts tightened faster and a more productive work team.

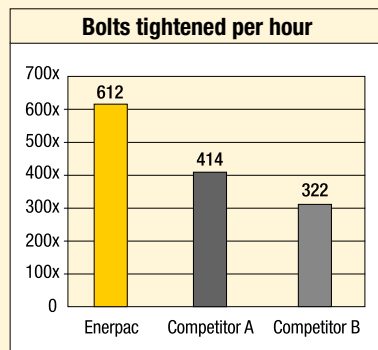

*Internal laboratory testing based on standard torqueing procedure on a pipe flange with 14, 1 7/8" bolts.*

## TQ Series



Reservoir Capacity:  
**4,0 litres**

Flow at Rated Pressure:  
**0,5 l/min**

Motor Size:  
**0,75 kW**

Maximum Operating Pressure:  
**700 bar**



### Torque Wrench Pump Selection

For optimum speed and performance see the torque wrench, pump and hose selection matrix.

Page: 40

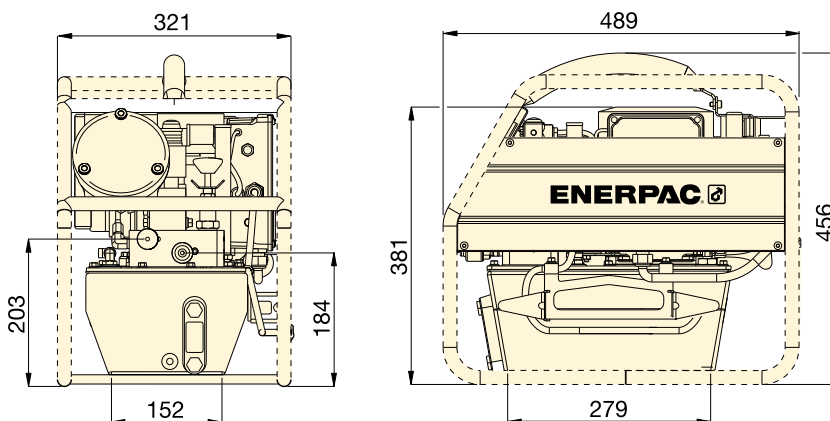

For Use with Torque Wrenches	Pressure Rating (bar)	Model Number <sup>1)</sup>	Useable Oil Capacity (litres)	Motor Size (kW)	Motor Electrical Specifications (Volt - Ph - Hz)	Sound Level (dBA)	Weight (kg)
All S and W-Series	700	<b>TQ-700B</b>	4,0	0,75	115 - 1 - 50/60	82 - 85	31
	700	<b>TQ-700E</b> <sup>2)</sup>	4,0	0,75	230 - 1 - 50	82 - 85	30
	700	<b>TQ-700I</b> <sup>3)</sup>	4,0	0,75	230 - 1 - 60	82 - 85	30

<sup>1)</sup> All models meet CE safety requirements and all TÜV requirements.

<sup>2)</sup> TQ-700E with European plug and CE EMC directive compliant.

<sup>3)</sup> TQ-700I with NEMA 6-15 plug.

▼ The TQ-700E and the W-Series wrenches are a productive combination.



▼ PTA-1404



- Compact and portable
- Handle located directly over pump's center of gravity for greater ease in carrying
- High bypass (125 bar) for faster torque cycles
- High power-to-weight ratio suits all Enerpac torque wrenches
- Glycerine filled pressure gauge with scales reading in bar/psi
- Transparent overlays in Nm and Ft.lbs for all Enerpac torque wrenches provide a quick torque reference
- Internal safety relief valve, factory preset.



◀ *The compact PTA-Series pumps may easily be transported to jobsites, and are ideal for powering Enerpac torque wrenches such as this W-Series low profile tool.*

## Two-Stage Power in a Portable Design



### Torque Wrench Hoses

Use Enerpac twin safety hoses to connect your torque wrench to the pump.

For 700 bar	Model Nr.
6 m long, 2 hoses	<b>THQ-706T</b>
12 m long, 2 hoses	<b>THQ-712T</b>
For 800 bar	
6 m long, 2 hoses	<b>THC-7062</b>
12 m long, 2 hoses	<b>THC-7122</b>



### Gauge and Overlay Kit

Available separately for use with PTA-Series pumps: **GT-4015Q** includes gauge and overlays for all S and W-Series wrenches.

**GT-4015** includes gauge and overlays for all SQD and HXD-Series wrenches.

# Compact Pneumatic Torque Wrench Pump

## PTA Series



Reservoir Capacity:

**3,8 litres**

Flow at Rated Pressure:

**0,33 l/min**

Air Consumption:

**1133 l/min**

Maximum Operating Pressure:

**700 - 800 bar**

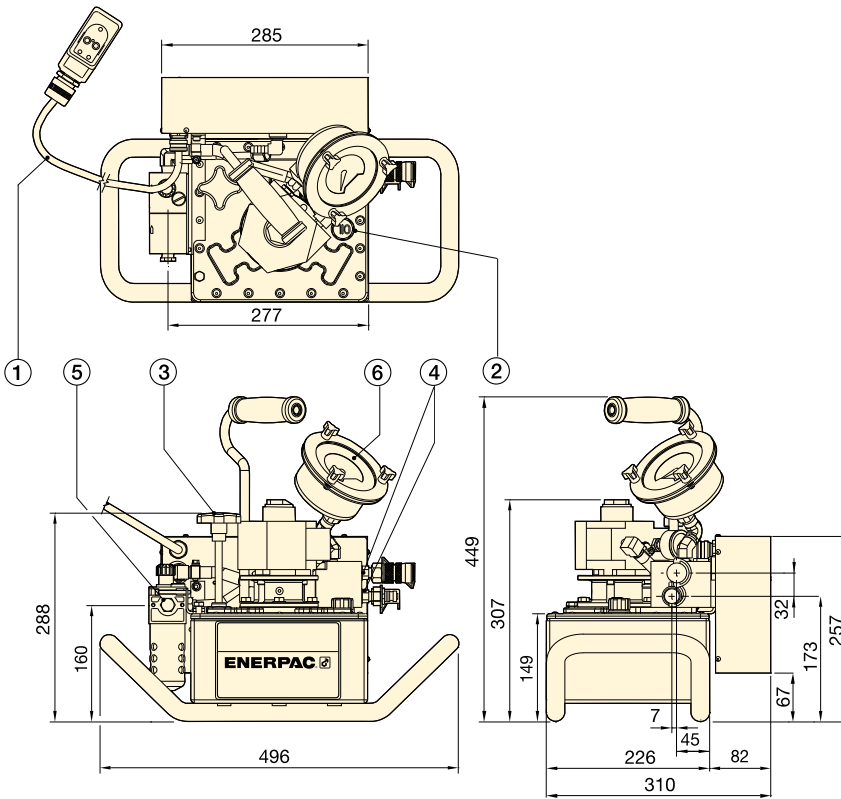

- ① 5 mtr Air control pendant
- ② Vent/Fill plug
- ③ Externally adjustable relief valve
- ④ 1/4" - 18 NPTF Hydraulic ports
- ⑤ 3/8" - 18 NPTF Air inlet
- ⑥ Gauge with overlay kit



### Torque Wrench Pump Selection

For optimum speed and performance see the torque wrench pump and hose selection matrix.

Page: **40**

### OIL FLOW VERSUS PRESSURE

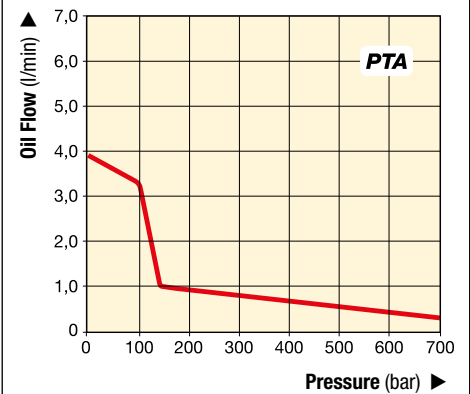

### ▼ PERFORMANCE CHART

For Use With Torque Wrenches		Pressure Rating		Model Number	Oil Flow Rate		Reservoir Capacity	Useable Oil	Air Consumption at 7 bar	Air Pressure Range	Weight
		(bar)	(bar)		(l/min)	(l/min)					
		1st stage	2nd stage		1st stage	2nd stage	(litres)	(litres)	(l/min)	(bar)	(kg)
S1500X S3000X	W2000X W4000X	125	<b>700</b>	<b>PTA-1404-Q</b>	3,9	0,33	3,8	1,9	1133	3,4 - 7,0	24,5
SQD-25-I SQD-50-I	HXD-30 HXD-60	125	<b>800</b>	<b>PTA-1404</b>	3,9	0,33	3,8	1,9	1133	3,4 - 7,0	24,5

# ZA4T-Series, Air Driven Torque Pumps

▼ ZA4204TX-ER



- Two-speed operation and high by-pass pressure reduces cycle time for improved productivity
- Glycerin filled pressure gauge with transparent overlays in Nm and Ft.lbs for Enerpac torque wrenches provide a quick torque reference
- Standard Regulator-Filter-Lubricator with removable bowls and auto drain
- Heat exchanger warms exhaust air to prevent freezing and cools the oil
- Ergonomic pendant allows remote operation up to 6 m.

## Complete 700 bar Pump-Hose Set ZA4208TX-QRU105

- Fine air pressure adjustment for very accurate torque control
- Improved wrench performance at low pressure
- Standard with THQ706T twin hose.



# Z

Tough,  
Dependable  
Innovative  
**CLASS**



### Torque Wrench Hoses

Use Enerpac twin safety hoses to connect your torque wrench to the pump.

For 700 bar	Model Nr.
6 m long, 2 hoses	<b>THQ-706T</b>
12 m long, 2 hoses	<b>THQ-712T</b>
For 800 bar	
6 m long, 2 hoses	<b>THC-7062</b>
12 m long, 2 hoses	<b>THC-7122</b>



### Gauge and Overlay Kit

Available separately for use with ZA4T-Series pumps: **GT-4015Q** includes gauge and overlays for all S- and W-Series wrenches.

**GT-4015** includes gauge and overlays for all SQD and HXD-Series wrenches.



### Torque Wrench Pump Selection

For optimum speed and performance see the torque wrench pump and hose selection matrix.

Page: **40**

◀ Most hydraulic torque wrenches can be powered by the Enerpac ZA4T-Series torque wrench pump.

# Air Driven Torque Wrench Pumps



## Pump Applications

The ZA4T-Series pump is best suited to power medium to large size torque wrenches.

Patent-pending Z-Class technology provides high by-pass pressures for increased productivity. Its high power to weight ratio and compact design make it ideal for applications which require easy transport of the pump.

All ZA4T-Series pump models meet CE, CSA and TÜV safety requirements. For further application assistance contact your local Enerpac office.

## ATEX 95 Certified

The ZA4T-Series pumps are tested and certified according to the Equipment Directive 94 / 9 / EC "ATEX Directive".

The explosion protection is for equipment group II, equipment category 2 (hazardous area zone 1), in gas and/or dust atmospheres. The ZA4T-Series pumps are marked with: Ex II 2 GD ck T4.



## ZA4T Series



Reservoir Capacity:

**4,0 - 8,0 litres**

Flow at Rated Pressure:

**0,8 - 1,0 l/min**

Air Consumption:

**600 - 2840 l/min**

Maximum Operating Pressure:

**700 - 800 bar**



## Accessory Options

Available by placing the following additional suffix at the end of the model number:

- K** = Skid bar
- M** = 4-wrench manifold
- R** = Roll cage.

Page: **53**

## OIL FLOW VERSUS PRESSURE

6,9 bar dynamic air pressure at 2840 l/min

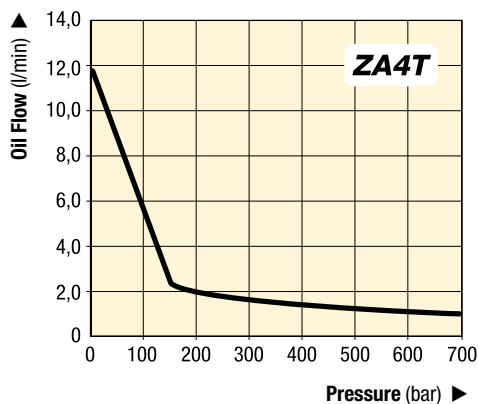

## COMMON PUMP MODELS

For Use With Torque Wrenches	Maximum Operating Pressure (bar)	Model Number	Usable Oil Capacity (litres)	Weight (kg)
All S and W-Series	700	ZA4208TX-QRU105 *	6,6	45
	700	ZA4204TX-Q	2,7	42
	700	ZA4208TX-Q	6,6	47
	700	ZA4204TX-QR	2,7	46
	700	ZA4208TX-QR	6,6	51
All SQD and HXD-Series	800	ZA4204TX-E	2,7	42
	800	ZA4208TX-E	6,6	47
	800	ZA4204TX-ER	2,7	46
	800	ZA4208TX-ER	6,6	51

\* Standard with THQ706T hose and fine air pressure adjustment for very accurate torque control.



# ZA4T-Series, Ordering Matrix and Specifications

▼ This is how a ZA4T-Series pump model number is built up:

<b>Z</b>	<b>A</b>	<b>4</b>	<b>2</b>	<b>08</b>	<b>T</b>	<b>X</b>	<b>-</b>	<b>Q</b>	<b>M</b>	<b>R</b>
1	2	3	4	5	6	7	8	8	8	
Product Type	Motor Type	Flow Group	Valve Type	Reservoir Size	Valve Operation	Voltage	Must be E or Q	Options	Options	

<p><b>1 Product Type</b> Z = Pump series</p> <p><b>2 Motor Type</b> A = Air motor</p> <p><b>3 Flow Group</b> 4 = 1,0 l/min @ 700 bar</p> <p><b>4 Valve Type</b> 2 = Torque Wrench Valve</p> <p><b>5 Reservoir Size</b> 04 = 2,7 litres useable oil 08 = 6,6 litres useable oil</p>	<p><b>6 Valve Operation</b> T = Air operated valve with pendant</p> <p><b>7 Voltage</b> X = Not applicable</p> <p><b>8 Options</b> E = with 800 bar couplers for use with HXD and SQD-Series or other wrenches Q = with 700 bar couplers for use with S and W-Series or other wrenches K = Skid bar M = 4-wrench manifold R = Roll cage</p>
--	---



**How to order your ZA4T-Series torque wrench pump**

Model No. ZA4208TX-QMR

700 bar pump for use with Enerpac S- and W-Series and other 700 bar hydraulic torque wrenches, 8 litres reservoir, 4-wrench manifold, and roll cage.

Refer to the selection matrix for optimum wrench, pump and hose combinations.



**Torque Wrench Hoses**

Use Enerpac twin safety hoses to connect your torque wrench to the pump.

For 700 bar	Model Nr.
6 m long, 2 hoses	THQ-706T
12 m long, 2 hoses	THQ-712T
For 800 bar	
6 m long, 2 hoses	THC-7062
12 m long, 2 hoses	THC-7122

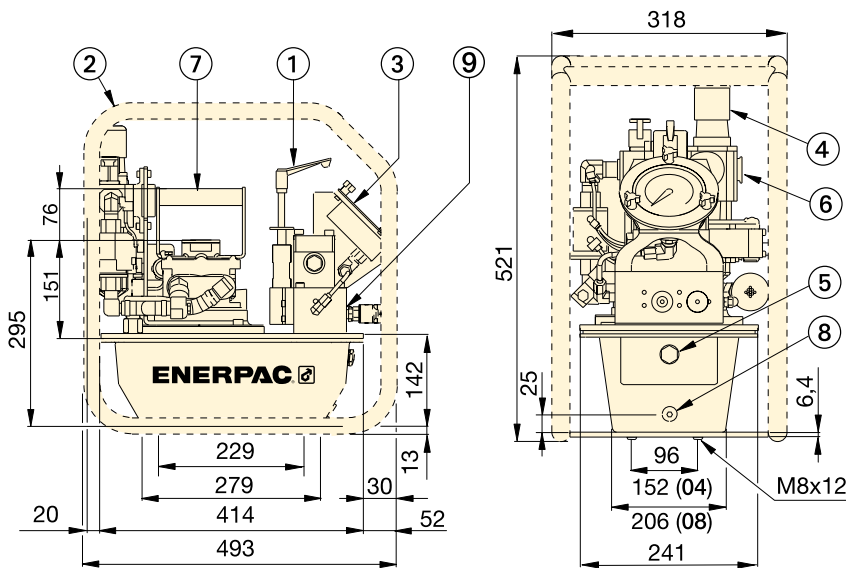

- ① User adjustable relief valve
- ② Roll Cage (optional)
- ③ Gauge with overlays
- ④ Filter/lubricator/regulator
- ⑤ Oil level sight gauge
- ⑥ Air input 1/2" NPTF
- ⑦ Standard handle
- ⑧ Oil drain
- ⑨ 1/4"-18 NPTF Oil outlet

ZA4T-Series Performance								
Output Flow Rate (l/min)				Dynamic Air Pressure Range (bar)	Air Consumption (l/min)	Sound Level (dBA)	Relief Valve Adjustment Range (bar)	
7 bar	50 bar	350 bar	700 bar					
11,5	8,8	1,2	1,0	4,0 - 6,9	600 - 2840	85-90	124-700 *	
5,4 **	4,8 **	1,1 **	0,8 **	7,0 **				

\* Pump type (-Q) shown, (-E) range is 124-800 bar.  
\*\* ZA4208TX-QRU105 only.

▼ Most hydraulic torque wrenches can be powered by the Enerpac ZA4T-Series torque wrench pump.





# ZA4T-Series, Pump Options



## Skid Bar

- Provides greater pump stability on soft or uneven surfaces
- Provides easy two-handed lift.

Accessory Kit * Model Nr.	Can be used on ZA4T-Series torque wrench pumps
<b>SBZ-4</b>	04 and 08 reservoir

\* Add suffix **K** for factory installation.  
Weight skid bar 2,2 kg.  
Ordering Example: **ZA4208TX-QK**



## 4-Wrench Manifold

- For simultaneous operation of multiple torque wrenches
- Can be factory installed or ordered separately.

Accessory Kit * Model Nr.	Can be used on ZA4T-Series torque wrench pumps
<b>ZTM-E</b>	for 800 bar wrenches
<b>ZTM-Q</b>	for 700 bar wrenches

\* Add suffix **M** for factory installation.  
Weight manifold 4,5 kg.  
Ordering Example: **ZA4208TX-QM**

## ZA4T Series



Reservoir Capacity:

**4,0 - 8,0 litres**

Flow at Rated Pressure:

**0,8 - 1,0 l/min**

Air Consumption:

**600 - 2840 l/min**

Maximum Operating Pressure:

**700 - 800 bar**



## 700 bar Spin-on Couplers

Model-Nr: TH-630 male coupler  
TR-630 female coupler

- Mounted on:
  - Torque wrench pumps with suffix "Q"
  - S and W-Series wrenches
  - THQ-Series hoses
  - 4-Wrench manifold ZTM-Q.



## 800 bar Lock-ring Couplers

Model-Nr: CMF-250 male coupler  
CFF-250 female coupler

- Mounted on:
  - Torque wrench pumps with suffix "E"
  - HXD and SQD-Series wrenches
  - THC-Series hoses
  - 4-Wrench manifold ZTM-E.



## Roll Cage

- Protects pump
- Provides greater pump stability

Accessory Kit * Model Nr.	Can be used on ZA4T-Series torque wrench pumps
<b>ZRC-04</b>	04 and 08 reservoir

\* Add suffix **R** for factory installation.  
Roll cage weight 3,4 kg.  
Ordering Example: **ZA4208TX-QR**

▼ Shown: GT-Series Bolt Tensioners



## Accurate & Reliable Extreme Performance Bolt Tensioner



### Tensioning Pumps, Hoses and Couplers

High pressure pumps, hoses and fittings matched for use with the Enerpac GT-Series Bolt Tensioning system.

Page: 59



### Minimum Stud Protrusion

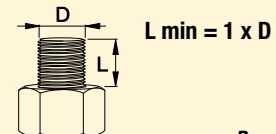

Page: 80

- Six load cells from M16 to M95 or from 5/8" to 3 3/4"
- Twin ports for quick connection of multiple tools
- Only one size of bridge per size of load cell
- Detachable and rotational bridge simplifies tool positioning
- Full bridge window
- Piston stroke indicator
- Black surface treatment protects against corrosion
- Anti-slip grip for more secure handling
- Universal and multi-use tool.

▼ GT-Series bolt tensioner used for tightening blade bolts of wind turbine.

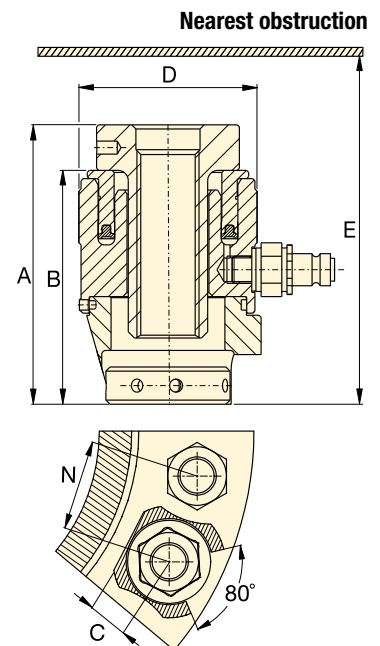

Bolt Range		Load Cell and Bridge Reference	Technical Data			Dimensions (mm)				 (kg)
(mm)	(inch)		Cylinder Effective Area (mm <sup>2</sup> )	Load Capacity (kN)	Stroke (mm)	A	B	C	D	
M16-M30	5/8"-1"	<b>GT1-LCB</b>	1495,4	224,3	10	135	113	27	86	3,0
M30-M39	1 1/8"-1 1/2"	<b>GT2-LCB</b>	2677,2	401,5	10	136	111	35	107	4,1
M39-M52	1 1/2"-2"	<b>GT3-LCB</b>	5127,1	768,9	10	160	126	46	138	7,0
M52-M68	2"-2 1/2"	<b>GT4-LCB</b>	9782,1	1466,9	10	180	141	62	174	12,2
M68-M80	2 1/2"-3 1/4"	<b>GT5-LCB</b>	15079,7	2261,4	10	202	157	78	210	18,7
M80-M95	3 1/4"-3 3/4"	<b>GT6-LCB</b>	18972,1	2845,1	10	219	173	82	240	27,8

# Hydraulic Bolt Tensioners

Load Cell and Bridge Reference	Thread Size	Adaptor Kit Model Number	Pitch Between Bolts N (mm)	Minimum Height E (mm)	 (kg)
GT1-LCB (224 kN)	M16 x 2	GT1PM-NRS01620	55	169	1,6
	M18 x 2,5	GT1PM-NRS01825	56	165	1,5
	M20 x 2,5	GT1PM-NRS02025	57	165	1,4
	M24 x 3	GT1PM-NRS02430	59	164	1,3
	M27 x 3	GT1PM-NRS02730	62	167	1,2
	M30 x 3,5	GT1PM-NRS03035	65	170	1,0
	5/8"-11UN	GT1P-NRS0625U11	55	169	1,6
	3/4"-10UN	GT1P-NRS0750U10	56	165	1,4
	7/8"-9UN	GT1P-NRS0875U09	59	164	1,3
	1"-8UN	GT1P-NRS1000U08	62	167	1,2
1 1/8"-8UN	GT1P-NRS1125U08	65	170	1,0	
GT2-LCB (401 kN)	M30 x 3,5	GT2PM-NRS03035	71	173	2,6
	M33 x 3,5	GT2PM-NRS03335	74	174	2,4
	M36 x 4	GT2PM-NRS03640	77	177	2,2
	M39 x 4	GT2PM-NRS03940	80	180	1,9
	1 1/8"-8UN	GT2P-NRS1125U08	71	173	2,6
	1 1/4"-8UN	GT2P-NRS1250U08	74	174	2,4
	1 3/8"-8UN	GT2P-NRS1375U08	77	177	2,2
1 1/2"-8UN	GT2P-NRS1500U08	80	180	2,0	
GT3-LCB (769 kN)	M39 x 4	GT3PM-NRS03940	92	212	5,7
	M42 x 4,5	GT3PM-NRS04245	96	215	5,4
	M45 x 4,5	GT3PM-NRS04545	99	218	5,0
	M48 x 5	GT3PM-NRS04850	105	216	4,7
	M52 x 5	GT3PM-NRS05250	108	220	4,2
	1 1/2"-8UN	GT3P-NRS1500U08	92	212	5,7
	1 5/8"-8UN	GT3P-NRS1625U08	96	215	5,3
	1 3/4"-8UN	GT3P-NRS1750U08	99	218	5,0
	1 7/8"-8UN	GT3P-NRS1875U08	105	216	4,6
2"-8UN	GT3P-NRS2000U08	108	220	4,2	
GT4-LCB (1467 kN)	M52 x 5	GT4PM-NRS05250	118	240	10,7
	M56 x 5,5	GT4PM-NRS05655	121	244	10,1
	M60 x 5,5	GT4PM-NRS06055	124	248	9,4
	M64 x 6	GT4PM-NRS06460	127	252	8,8
	M68 x 6	GT4PM-NRS06860	130	256	8,1
	2"-8UN	GT4P-NRS2000U08	118	240	10,7
	2 1/4"-8UN	GT4P-NRS2250U08	121	244	9,7
2 1/2"-8UN	GT4P-NRS2500U08	127	252	8,5	
GT5-LCB (2261 kN)	M68 x 6	GT5PM-NRS06860	145	278	17,3
	M72 x 6	GT5PM-NRS07260	149	282	16,4
	M76 x 6	GT5PM-NRS07660	152	286	15,5
	M80 x 6	GT5PM-NRS08060	162	293	14,6
	2 1/2"-8UN	GT5P-NRS2500U08	144	274	17,8
	2 3/4"-8UN	GT5P-NRS2750U08	149	282	16,3
	3"-8UN	GT5P-NRS3000U08	152	286	14,8
3 1/4"-8UN	GT5P-NRS3250U08	162	293	13,1	
GT6-LCB (2845 kN)	M80 x 6	GT6PM-NRS08060	169	312	22,3
	M85 x 6	GT6PM-NRS08560	169	312	21,0
	M90 x 6	GT6PM-NRS09060	178	317	19,4
	M95 x 6	GT6PM-NRS09560	181	322	18,0
	3 1/4"-8UN	GT6P-NRS3250U08	169	312	20,7
	3 1/2"-8UN	GT6P-NRS3500U08	178	317	18,8
3 3/4"-8UN	GT6P-NRS3750U08	181	322	16,8	

## GT Series



Bolt Range:

**M16 - M95, 5/8" - 3 3/4"**

Maximum Load:

**2845 kN**

Maximum Operating Pressure:

**1500 bar**



### How to Order

To provide maximum flexibility Load Cell and Bridges are ordered separately from Adaptor Kits.

Example, to order a complete tensioner for a M36 x 4 threaded bolt order:

1 x Load Cell and Bridge: **GT2-LCB**

1 x Adaptor Kit: **GT2PM-NRS03640**



### Bolting Integrity Software

A comprehensive on-line software solution for Bolted Joint integrity at [www.enerpac.com](http://www.enerpac.com)

Integral databases hold data for:

- BS1560, MSS SP44, API 6A and 17D flanged joints
- Common gasket materials and configurations
- Comprehensive range of bolt materials
- Comprehensive range of lubricants
- Enerpac's Controlled Bolting Equipment including: Torque Multipliers, Hydraulic Wrenches and Bolt Tensioning tools.

Custom Joint information can also be entered.

The software offers Tool selection, Bolt Load calculations and Tool pressure settings, as well as, a combined Application data sheet and Joint completion report.

▼ ZUTP-1500E



## ZUTP Series

Reservoir Capacity:  
**4,0 litres**

Flow at Rated Pressure:  
**0,13 l/min**

Maximum Operating Pressure:  
**1500 bar**

- Two-stage pump design provides high flow at low pressure for fast system fills and controlled flow at high pressure for safe and accurate operation
- 6 m pendant cord enables motor control from a distance
- Angled 153 mm pressure gauge, with polycarbonate cover, built into a protective metal shroud for improved visibility and protection
- Safety relief valve limits output pressure
- Compact, lightweight and rugged aluminium frame for increased durability and ease of handling.



### Applications

The Enerpac ZUTP-Series electric pump is ideally suited for use with hydraulic bolt tensioning tools and hydraulic nuts.

Page: **56**



### 1500 bar hoses and couplers

This pump operates at ultra-high pressure, use only the specified fittings and hoses designed for these pressures.

Page: **59**



### Bolting Theory

See our 'Yellow Pages' for information on torque tightening and tensioning.

Page: **72**

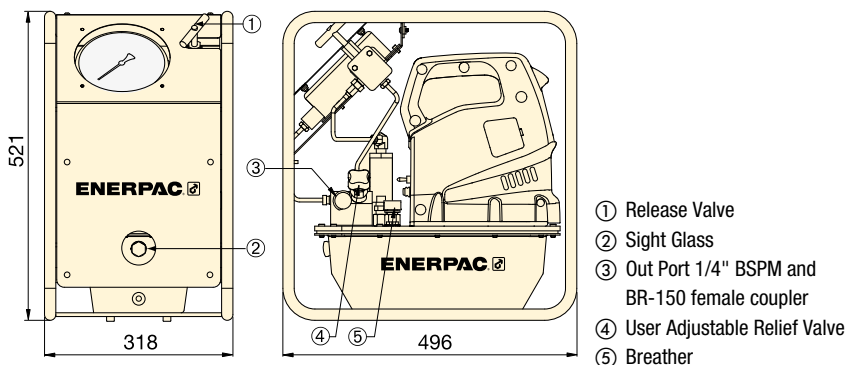

### 1500 bar HIGH PRESSURE PUMP

Pump Type	Useable Oil Capacity (litres)	Model Number <sup>1)</sup>	Pressure Rating (bar)	Output Flow Rate at 0 bar (l/min)	Output Flow Rate at 1500 bar (l/min)	Motor Electrical Specification	Motor Size (kW)	Sound Level (dBA)	 (kg)
Two speed	4,0	<b>ZUTP-1500 B</b>	1500	2,90	0,13	115 VAC, 1-ph	1,25	89	29,5
	4,0	<b>ZUTP-1500 E <sup>2)</sup></b>	1500	2,90	0,13	230 VAC, 1-ph <sup>2)</sup>	1,25	89	29,5
	4,0	<b>ZUTP-1500 I <sup>3)</sup></b>	1500	2,90	0,13	230 VAC, 1-ph <sup>3)</sup>	1,25	89	29,5

<sup>1)</sup> All models meet CE safety requirements and all TÜV requirements.

<sup>2)</sup> European plug and CE EMC directive compliant.

<sup>3)</sup> With NEMA 6-15 plug.

# High Pressure Hand Pump and Accessories

▼ HPT-1500



- Lightweight and portable high-pressure hand pump
- Two-speed operation displaces a larger volume of oil per stroke, reducing cycle times for many testing applications
- Includes a pressure gauge and coupler for direct connection to Enerpac GT-Series Bolt Tensioners
- Integrated relief valve set at 1500 bar.

## HPT, HT, B Series

Reservoir Capacity:

**2,5 litres**

Flow at Rated Pressure:

**0,61 cm<sup>3</sup>/stroke**

Maximum Operating Pressure:

**1500 bar**



### Ultra-high pressure

This pump operates at ultra-high pressure, use only the specified fittings and hoses designed for these pressures.



### Applications

The hand pump is ideally suited for use with hydraulic bolt tensioning tools and hydraulic nuts.



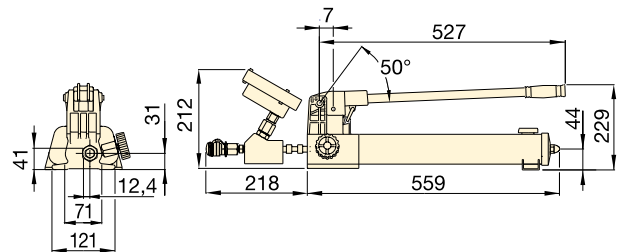

Page: **56**



### 1500 bar ULTRA-HIGH PRESSURE PUMP



Pump Type	Useable Oil Capacity (litres)	Model Number	Pressure Rating (bar)		Oil Displacement per Stroke (cm <sup>3</sup> )		High Pressure Oil Port with female coupler	 (kg)
			1st stage	2nd stage	1st stage	2nd stage		
Two Speed	2,54	<b>HPT-1500</b>	14	1500	16,22	0,61	1/4" BSPP + BR-150	9,0

### 1500 bar HOSES

Model Number		Hose End 1	Hose End 2	Length (m)
HT-1503		1/4" BSPM 120° Cone	1/4" BSPM 120° Cone	1,0
HT-1510		1/4" BSPM 120° Cone	1/4" BSPM 120° Cone	3,0
HT-1503HR*		<b>BH-150</b>	<b>BR-150</b>	1,0
HT-1510HR*		<b>BH-150</b>	<b>BR-150</b>	3,0

\* Includes dust caps.

### 1500 bar COUPLERS

Description		Complete Set	Female Half	Male Half
Quick Disconnect Coupler *		<b>B-150</b>	<b>BR-150</b>	<b>BH-150</b>
Quick Disconnect Coupler and Adaptor Kit *		<b>BW-150AW</b>	-	-
Quick Disconnect Blanking Coupler Set *		<b>B-150B</b>	-	-

\* Includes dust caps.

# Ultra-High Pressure Air Pump

▼ ATP-1500



- General purpose, high pressure air driven two speed pump unit for products requiring up to 1500 bar hydraulic pressure
- Compact, lightweight, rugged steel frame for protection and easy handling
- Pre-lubricated pump element, does not require an airline lubricator
- Easily adjustable output pressure control
- Integrated and protected easy to read glycerin filled gauge
- Safety relief valve limits output pressure.

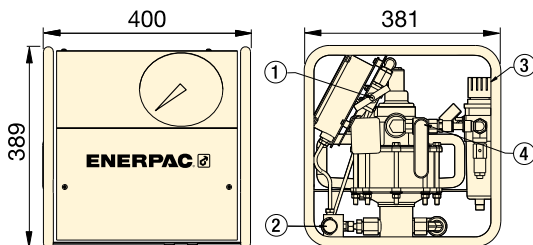

- Shut-off Valve
  - Outlet Port 1/4" BSPM with BR-150 female coupler
  - Filter/Regulator
  - Air On/Off Valve
- Air Inlet 1/2" NPTF

## 1500 bar HIGH PRESSURE AIR PUMP

Pump Type	Useable Oil Capacity (litres)	Pressure Rating (bar)	Model Number	Output Flow Rate at 0 bar (l/min)	Output Flow Rate at 1500 bar (l/min)	Air Pressure Range (bar)	Air Consumption (l/min)	Sound Level (dBA)	 (kg)
Two speed	3,8	1500	<b>ATP-1500</b>	0,43	0,07	5,5 - 6,2	594	70	32

## ATP Series

Reservoir Capacity:  
**3,8 litres**

Flow at Rated Pressure:  
**0,07 l/min**

Maximum Operating Pressure:  
**1500 bar**



### Ultra-high pressure

This pump operates at ultra-high pressure, use only the specified fittings and hoses designed for these pressures.

Page: **59**



### Applications

The Enerpac ATP-Series air pump is ideally suited for use with hydraulic bolt tensioning tools and hydraulic nuts.

Page: **56**



### ATEX Certified

The ATP-Pump is tested and certified according ATEX.



II 2 GD ck T4

Page: **72**

### OIL FLOW VERSUS PRESSURE

Flow (l/min) at 6,2 bar air input

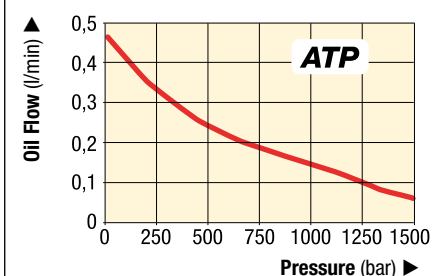

# Power Box – Portable Tool Sets

▼ SCR154PGH



- Easy to carry sturdy tool box
- Complete and ready-to-use hydraulic sets
- Includes a single-acting cylinder, two-speed lightweight hand pump, gauge adaptor assembly, 1,8 m hose and couplers.

**SC,  
SL,  
SR,  
SW  
Series**



Capacity:

**1 - 45 ton**

Stroke:

**11 - 156 mm**







Maximum Operating Pressure:

**700 bar**



#### Gauge Adaptor Assembly

Power Box Sets include 45 degree angled gauge adaptor assembly for improved safe working conditions.

	Cylinder Model	Cylinder Stroke (mm)	Cylinder Capacity ton (kN)	 Weight (kg)	Power Box Model Number
	<b>Lifting Wedge</b>				
	LW-16	21	16 (157)	9,0	SLW16PGH
	<b>Wedge Spread Cylinder</b>				
	WR-5	94 <sup>1)</sup>	1,0 (8,9)	12,0	SWR5PGH
	<b>General Purpose Cylinders</b>				
	RC-102	54	10 (101)	12,3	SCR102PGH
	RC-106	156	10 (101)	14,4	SCR106PGH
	RC-154	101	15 (142)	15,0	SCR154PGH
	RC-156	152	15 (142)	16,8	SCR156PGH
	<b>Low Height Cylinders</b>				
	RCS-101	38	10 (101)	14,1	SCL101PGH
	RCS-201	45	20 (201)	15,0	SCL201PGH
	<b>Flat-Jac® Cylinders</b>				
	RSM-100	11	10 (101)	11,4	SRS100PGH
	RSM-200	11	20 (201)	13,1	SRS200PGH
	RSM-300	13	30 (295)	14,5	SRS300PGH
	RSM-500	16	45 (435)	16,8	SRS500PGH

<sup>1)</sup> Maximum spread of WR-5.

▼ The Power Box – the portable tool set – applicable everywhere.



▼ SCR-1010H cylinder-pump set



## The Quickest and Easiest Way to Start Working Right Away



### LW-16 Lifting Wedge

Hydraulic cylinders, jacks and lifting wedges can also be used to assist in positioning and aligning. The LW-16 only requires an access



gap of 10 mm. See our "Specialty Tools" section on [www.enerpac.com](http://www.enerpac.com).

Page: **61**

- Optimum match of individual components
- All sets are ready-for-use and include single-acting cylinder, two-speed pump, 1,8 m safety hose and gauge and adaptor
- Choice between handpump, air driven foot pump or cordless pump
- RC-Series DUO, General Purpose Cylinders: for maximum versatility
- RCS-Series, Low Height Cylinders: ideal where space is restricted
- RCH-Series, Hollow Plunger Cylinders: for pushing and pulling applications.

▼ Cylinder-Pump Sets – optimum match of components. The quickest and easiest way to start working right away.



1 Cylinder Selection	Set Capacity ton (kN)	Cylinder Model Number	Stroke (mm)	Collapsed Height (mm)
	5 (45)	RC-55	127	215
		RC-102	54	121
	10 (101)	RC-106	156	247
		RC-1010	257	349
		RC-154	101	200
15 (142)	RC-156	152	271	
	25 (232)	RC-252	50	165
		RC-254	102	215
RC-256		158	273	
RC-2514	362	476		
50 (498)	RC-506	159	282	
	10 (101)	RCS-101	38	88
	20 (201)	RCS-201	45	98
	30 (295)	RCS-302	62	117
	45 (435)	RCS-502	60	122
	90 (887)	RCS-1002	57	141
	13 (125)	RCH-121	42	120
	20 (215)	RCH-202	49	162
	30 (326)	RCH-302	64	178
	60 (576)	RCH-603	76	247
	95 (933)	RCH-1003	76	254



# Single-Acting Cylinder-Pump Sets

## SET SELECTION:

- 1 Select the cylinder
- 2 Select the pump
- 3 Find the set model number in the gray matrix

## SELECTION EXAMPLE

### Selected cylinder:

- RC-106, Single-Acting cylinder with 156 mm stroke

### Selected pump:

- P-392, Lightweight hand pump

### Set model number:

- SCR-106H

### Included:

- HC-7206 hose
- GF-10B gauge
- GA-2 adaptor

## SC Series



Capacity:

**5 - 95 ton**

Stroke:

**38 - 362 mm**

Maximum Operating Pressure:

**700 bar**



### Power Box

Portable tool box with hand pump, gauge adaptor assembly, hose and RC-, RCS, RSM, WR or LW-Series cylinder.

Page: **61**

2

Pump selection (See enerpac.com for full product descriptions.)

Accessories included

3

Hand Pump P-142	Hand Pump P-392	Hand Pump P-80	Foot Pump P-392FP	XA-Series Air Pump XA-11	XC-Series Cordless Pump XC-1201ME <sup>2)</sup>	Hose Model Number	Gauge Model Number	Gauge Adaptor Model Nr.
SCR-55H	-	-	-	-	-	HC-7206	GP-10S	GA-4
-	SCR-102H	-	SCR-102FP	SCR-102XA	SCR-102XCE	HC-7206	GF-10B	GA-2
-	SCR-106H	-	SCR-106FP	SCR-106XA	SCR-106XCE	HC-7206	GF-10B	GA-2
-	SCR-1010H	-	SCR-1010FP	SCR-1010XA	SCR-1010XCE	HC-7206	GF-10B	GA-2
-	SCR-154H	-	SCR-154FP	SCR-154XA	SCR-154XCE	HC-7206	GP-10S	GA-2
-	SCR-156H	-	SCR-156FP	SCR-156XA	SCR-156XCE	HC-7206	GP-10S	GA-2
-	SCR-252H	-	SCR-252FP	SCR-252XA	SCR-252XCE	HC-7206	GF-20B	GA-2
-	SCR-254H	-	SCR-254FP	SCR-254XA	SCR-254XCE	HC-7206	GF-20B	GA-2
-	SCR-256H	-	-	SCR-256XA	SCR-256XCE	HC-7206	GF-20B	GA-2
-	-	SCR-2514H	-	SCR-2514XA <sup>1)</sup>	-	HC-7206	GF-20B	GA-2
-	-	SCR-506H	-	SCR-506XA <sup>1)</sup>	-	HC-7206	GF-50B	GA-2
-	SCL-101H	-	SCL-101FP	SCL-101XA	-	HC-7206	GF-10B	GA-2
-	SCL-201H	-	SCL-201FP	SCL-201XA	-	HC-7206	GF-230B	GA-2
-	SCL-302H	-	SCL-302FP	SCL-302XA	SCL-302XCE	HC-7206	GF-230B	GA-2
-	SCL-502H	-	SCL-502FP	SCL-502XA	SCL-502XCE	HC-7206	GF-510B	GA-2
-	-	SCL-1002H	-	-	SCL-1002XCE	HC-7206	GF-510B	GA-2
SCH-121H	-	-	-	-	-	HB-7206	GF-120B	GA-4
-	SCH-202H	-	SCH-202FP	SCH-202XA	SCH-202XCE	HC-7206	GF-813B	GA-3
-	SCH-302H	-	SCH-302FP	SCH-302XA	SCH-302XCE	HC-7206	GF-813B	GA-3
-	-	SCH-603H	-	SCH-603XA <sup>1)</sup>	SCH-603XCE	HC-7206	GF-813B	GA-3
-	-	SCH-1003H	-	-	-	HC-7206	GP-10S	GA-2

<sup>1)</sup> With XA-12 air pump.

<sup>2)</sup> Cordless Pump includes 230V Charger. For 115V charger replace the "E" by the "B" in the model number.

# ATM-Series, Flange Alignment Tools

▼ From left to right: ATM-4, ATM-9, ATM-2 (ATM-9 shown without pump and hose)



- Enerpac ATM-Series tools rectify twist and rotational misalignment quickly, safely and without the need for an external power source
- Appropriate for use on most ANSI, API, BS and DIN flanges
- Reduces set-up time: no need for chains, pulleys or rigs
- Safety strap helps provide secure operation
- Can be installed and used in any position
- Portable, lightweight design enables easy transport and use, even in remote locations.

▼ The compact ATM-2 is actuated by simply hand turning the crank.



## ATM Series

Minimum Bolt Size:

**16 - 31,5 mm**

Flange Wall Thickness:

**14 - 228 mm**

Maximum Lifting Force:

**1 - 9 ton (10 - 90 kN)**



### Adjustable Reach

The highly adjustable reach of the wing and drop leg on ATM-4 and ATM-9 allow precise alignment.



### ATM-9 Hydraulics

The ATM-9 includes P-142 hand pump and HC-7206C 1,8 m long hose. Enerpac recommend the use of the pressure gauge **GP-10S** and gauge adaptor **GA-4** for easy mounting of the gauge onto your system.

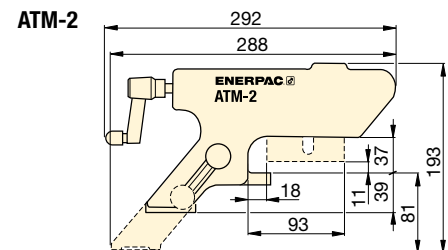

ATM-4

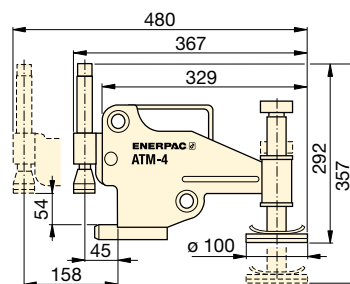

ATM-9

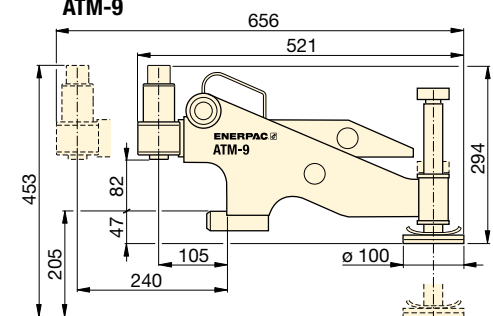

Maximum Lifting Force		Model Number	Minimum Bolt Size		Flange Wall Thickness		 (kg)
ton	kN		(mm)	(inch)	(mm)	(inch)	
1	10	ATM-2	16	.63	14 - 82	.55 - 3.29	1,6
4	40	ATM-4	24	.95	30 - 133	1.18 - 5.23	8,6
9	90	ATM-9 *	31,5	1.24	93 - 228	3.66 - 9.00	14,5

\* ATM-9 includes an Enerpac hand pump and hydraulic hose (gauge and adaptor sold separately).  
ATM-9 weight includes tool only.

# NC-Series, Single-Acting Hydraulic Nut Splitters

▼ Shown from left to right: NC-3241, NC-1319, NC-1924



- Compact and ergonomic design, easy to use
- Unique angled head design
- Two blade design (NC-D models) for time saving operation – nuts are split from two sides in one action
- Single-acting, spring return cylinder
- Heavy duty chisels can be reground
- Nut Splitters include spare chisel, spare set screw and wrench used to secure the chisel. A CR-400 coupler is standard.

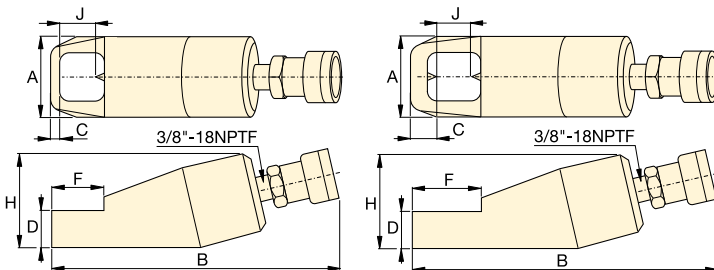

Single Blade Models (NC)

Double Blade Models (NC-D)

## NC, STN Series

Hexagon Nut Range:  
**10 - 75 mm**

Bolt Range:  
**M6 - M48**

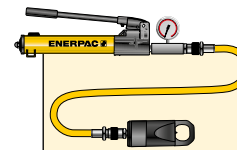

Maximum Operating Pressure:  
**700 bar**



**Tool-Pump Sets**  
Hydraulic Nut Splitters are available as sets (pump, tool, gauge, gauge adaptor, couplers and hose) for your ordering convenience.

Nut Splitter Model Nr.	Hand Pump Model Nr.	Set Model Number
NC-1924	P-392	STN-1924H
NC-2432	P-392	STN-2432H
NC-3241	P-392	STN-3241H

For Nut Splitter Model Nr.	Replacement Chisel Model Numbers	
	Moving	Static
NC-1319	NCB-1319	-
NC-1924	NCB-1924	-
NC-2432	NCB-2432	-
NC-3241	NCB-3241	-
NC-4150	NCB-4150	-
NC-5060	NCB-5060	-
NC-6075	NCB-6075	-
NC-2432D	NCB-2432	NCB-2432D
NC-3241D	NCB-3241	NCB-3241D

	Bolt Range (mm)	Hexagon Nut Range (mm)	Capacity ton (kN)	Oil Capacity (cm <sup>3</sup> )	Model Number	Dimensions (mm)						 (kg)	
						A	B	C	D	F	H		J
	M6 - M12	10 - 19	5 (49)	15	NC-1319	40	170	7	19	28	48	21	1,2
	M12 - M16	19 - 24	10 (98)	20	NC-1924 *	54	191	10	26	40	62	25	2,0
	M16 - M22	24 - 32	15 (147)	60	NC-2432 *	64	222	13	29	51	72	33	3,0
	M22 - M27	32 - 41	20 (196)	80	NC-3241 *	75	244	17	36	66	88	43	4,4
	M27 - M33	41 - 50	35 (343)	155	NC-4150	94	288	21	45	74	105	54	8,2
	M33 - M39	50 - 60	50 (490)	240	NC-5060	106	318	23	54	90	128	60	11,8
	M16 - M22	24 - 32	15 (147)	60	NC-2432D	64	275	25	31	65	78	33	5,4
	M22 - M27	32 - 41	20 (196)	80	NC-3241D	77	305	31	37	80	90	43	7,2

Ordering Notes: Maximum allowable hardness to split is HRc-44. Not to be used on square nuts or stainless steel.

\* Available as Tool-Pump Set, see note on this page.

▼ NS-Series Hydraulic Nut Splitters



- Specially designed to suit standard ANSI B16.5 / BS1560 flanges
- Single-acting (spring return) cylinder
- Tri-blade technology provides three cutting surfaces on a single blade
- Interchangeable heads provide maximum nut range flexibility
- Preset scale allows controlled blade extension, which avoids damage to bolt threads
- Grip tape and handle included for more secure manoeuvrability
- Nickel-plated cylinder body for excellent corrosion protection and improved durability in harsh environments
- Internal pressure relief valve for overload protection.

▼ Heavily corroded and weathered nuts are quickly split and removed using a NS-Series Nut Splitter.



*Nut splitter set for joint separation during inspection, maintenance and decommissioning operations. ▶*

## Power and Precision High Performance Nut Splitter



### Blade Cutting Depth Scale

Adjustable cutting depth scale for controlled blade extension, which avoids damage to bolt threads. The scale indicates the

bolt range in metric and imperial values on each cutting head.



### Hydraulic Nut Cutters

The NC-Series models are available featuring an angled head design for 10 - 75 mm hexagon nuts.

Page: 65



### Joint Separation Tools

FS and FSH-Series flange spreaders provide quick and easy joint separation using hydraulic or mechanical force.

Page: 68



### Flange Alignment Tools

The ATM-Series provide safe and high-precision flange alignment tools that fit most commonly used ANSI, API, BS and DIN flanges.

Page: 64



# Single-Acting Hydraulic Nut Splitters



## Nut Splitter Sets

To provide maximum flexibility, NS-Series Nut Splitters can also be ordered in sets (NS-xxxSy).

Select Nut Splitter size and pump style from the chart below.

To order additional Cutting Heads (NSH-xxxxxx), Cylinders (NSC-xxx) or Replacement Blades (NSB-xxx), see Selection Chart below.

## SET SELECTION:

**1** Select your Nut Splitter

**2** Select your pump type

## NS Series



Capacity:

**917 - 1711 kN**

Hexagon Nut Size:

**70 - 130 mm**

Bolt Range:

**M45 - M90**

Maximum Operating Pressure:

**700 bar**

Nut Splitter Model Nr.	Nut Splitter & Pump Set Model Nr.	Pump Selection			Accessories Included			
		Hand Pump Model Nr.	Air Pump Model Nr.	Electric Pump Model Nr.	Pressure Gauge Model Nr.	Gauge Adaptor Model Nr.	Hydraulic Hose Model Nr.	Storage Case Model Nr.
NS-70105	<b>NS-70105SH</b>	P-392	-	-	GP-10S	GA-2	HC-7206	CM-4
NS-70105	<b>NS-70105SA</b>	-	XA-11G *	-	*	-	HC-7206	CM-4
NS-70105	<b>NS-70105SEE</b>	-	-	PUD-1100E	GP-10S	GA-2	HC-7206	CM-7
NS-110130	<b>NS-110130SH</b>	P-802	-	-	GP-10S	GA-2	HC-7206	CM-4
NS-110130	<b>NS-110130SA</b>	-	XA-11G *	-	*	-	HC-7206	CM-4
NS-110130	<b>NS-110130SEE</b>	-	-	PUD-1100E	GP-10S	GA-2	HC-7206	CM-7

\* XA-11G air pump features an integrated pressure gauge.

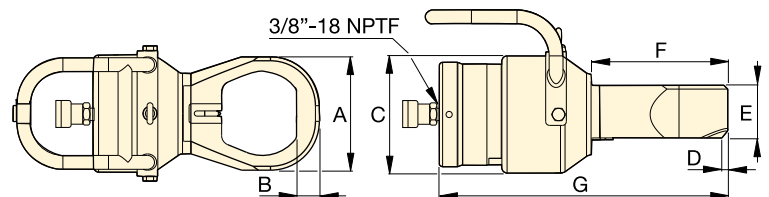

## SELECTION CHART

Bolt Range (mm)	Hexagon Nut Range <sup>1)</sup> (mm)	Capacity ton (kN)	Oil Capacity (cm <sup>3</sup> )	Model Number <sup>2)</sup> 	Dimensions (mm)							Cylinder <sup>3)</sup> 	Cutting Head <sup>3)</sup> 	Replacement Blade 	
					A	B	C	D	E	F	G				
<b>M45 - M52</b>	70 - 80	<b>103</b> (917)	377	<b>NS-7080</b>	132	28	180	8,0	81	186	412	37,0	NSC-70	NSH-7080	NSB-70
<b>M45 - M56</b>	70 - 85	<b>103</b> (917)	377	<b>NS-7085</b>	145	30	180	8,0	81	196	422	37,0	NSC-70	NSH-7085	NSB-70
<b>M45 - M64</b>	70 - 95	<b>103</b> (917)	377	<b>NS-7095</b>	160	32	180	8,0	81	201	432	38,5	NSC-70	NSH-7095	NSB-70
<b>M45 - M72</b>	70 - 105	<b>103</b> (917)	377	<b>NS-70105</b>	174	35	180	9,0	81	209	443	39,5	NSC-70	NSH-70105	NSB-70
<b>M76 - M80</b>	110 - 115	<b>193</b> (1711)	819	<b>NS-110115</b>	189	36	234	3,7	111	234	472	69,0	NSC-110	NSH-110115	NSB-110
<b>M76 - M90</b>	110 - 130	<b>193</b> (1711)	819	<b>NS-110130</b>	219	41	234	2,5	111	242	493	71,5	NSC-110	NSH-110130	NSB-110

<sup>1)</sup> Maximum allowable hardness to split is HRC-44. See page 82 for hexagon bolt and nut sizes and related thread diameters.

<sup>2)</sup> NS-Series Nut Splitters shipped in two cases: One containing the NSC-Cylinder and one containing the NSH-Cutting Head. Assembly required.

<sup>3)</sup> Both, the NSH-head and the NSC-cylinder include a cutting blade.

▼ Shown: FS-56



- **Lightweight, ergonomic design for ease of use**
- **Adjustable jaw widths from 70 to 216 mm for a wide range of applications**
- **Single-acting, spring return RC-Series DUO cylinder for fast trouble-free operation.**

## FS, STF Series

Capacity:  
**5 - 10 ton**

Maximum Operating Pressure:  
**700 bar**

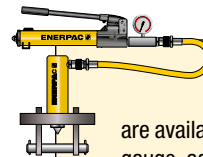

### Flange Spreader Sets

Both hydraulic flange spreaders are available as sets (includes pump, tool, gauge, adaptor and hose) for your ordering convenience.

Pump Model Nr.	Spreader Model Nr.	Set Model Number
P-392	FS-56	<b>STF-56H</b>
P-392	FS-109	<b>STF-109H</b>
PATG-1102N	FS-109	<b>STF-109A</b>



### Wedge Spreaders

Friction-free, smooth and parallel wedge movement with unique interlock wedge design. Eliminates flange damage and risk of spreading arm failure.

Page: **69**

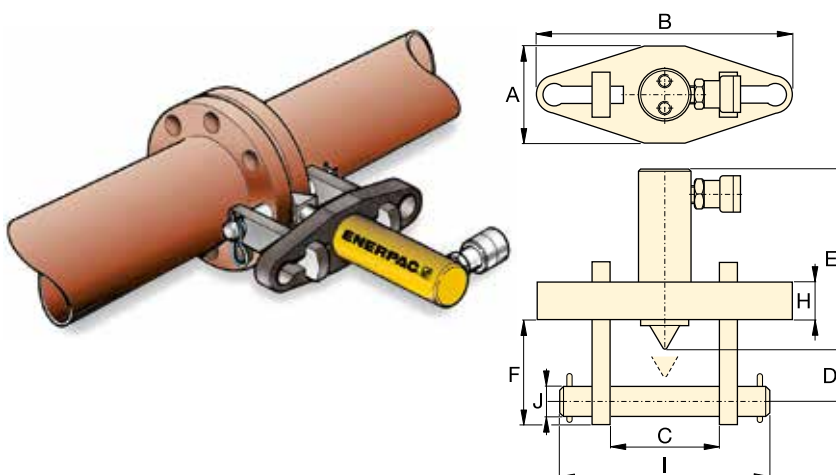

### Flange Spreader Matching Chart

ASA Rating (bar)	Pipe Size (mm)	
	FS-56	FS-109
10	127 - 508	558 - 1066
20	63 - 355	406 - 711
27	63 - 304	355 - 609
35	63 - 254	304 - 508
62	12 - 152	203 - 406
103	12 - 88	101 - 203
172	12 - 63	76 - 101

Maximum Flange Thickness (mm)	Stud Size (mm)	Standard Wedge (mm)	Capacity ton (kN)	Stroke (mm)	Oil Capacity (cm <sup>3</sup> )	Model Number	Dimensions (mm)										⚖️ (kg)
							A	B	C		D	E	F	H	I	J	
2 x 57	19 - 28	3 - 28	5 (45)	38	24,6	<b>FS-56</b>	76	209	70	155	32	196	88	25	206	19	11,5
2 x 92	31 - 41	3 - 28	10 (101)	54	78,7	<b>FS-109</b>	108	279	104	216	50	152	114	38	273	31	18,1

# Hydraulic and Mechanical Industrial Spreaders

▼ FSH-14 and FSM-8 with safety blocks SB-1



- **Integrated wedge concept:** friction-free, smooth and parallel wedge movement eliminates flange damage and spreading arm failure
- **Unique interlocking wedge design** - no first step bending and risk of slipping out of joint
- **Requires very small access gap of only 6 mm**
- **Stepped spreader arm design** - each step can spread under full load
- **Few moving parts mean durability and low maintenance**
- **Safety block SB-1 and ratchet spanner SW-22 included with FSM-8**
- **Safety block SB-1 and RC-102 cylinder included with FSH-14.**

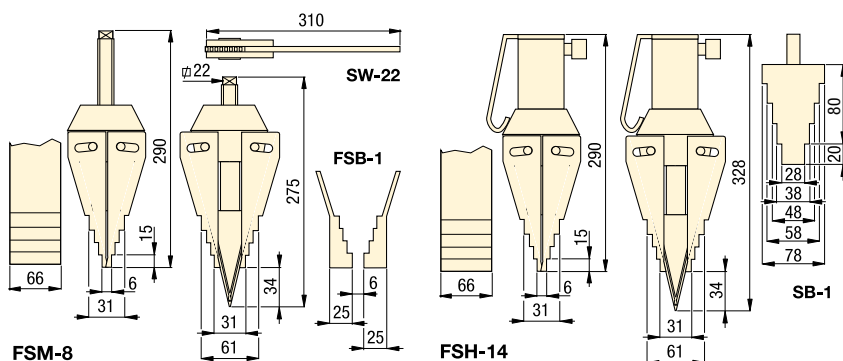

Maximum Spreading Force	Model Number	Tip Clearance	Maximum Spread <sup>1)</sup>	Spreader Type	Oil Capacity	
ton (kN)		(mm)	(mm)		(cm <sup>3</sup> )	(kg)
8 (72)	<b>FSM-8</b>	6	80	Mechanical	–	6,5
14 (125)	<b>FSH-14 *</b>	6	80	Hydraulic	78	7,1

<sup>1)</sup> Using stepped blocks FSB-1

\* Available as pump-tool set, see note on this page.

## FSH, FSM, STF Series

Tip Clearance / Maximum Spread:

**6 mm / 80 mm**

Maximum Spread Force:

**8 - 14 ton**

Maximum Operating Pressure:

**700 bar (FSH-14)**



### Stepped Blocks FSB-1

Use stepped blocks to increase wedge opening up to 80 mm. Fits both FSM-8 and FSH-14.

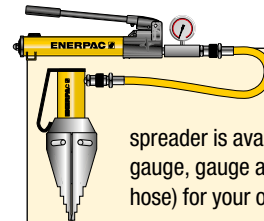

### Tool-Pump Set

The hydraulic flange spreader is available as set (pump, tool, gauge, gauge adaptor, couplers and hose) for your ordering convenience.

Spreader Model Nr.	Handpump Model Nr.	Set Model Number
FSH-14	P-392	<b>STF-14H</b>



### Cylinder-Pump Sets

Hydraulic cylinders can also be used to assist in pipe line positioning and aligning.

Page: **62**

▼ Flange maintenance and joint separation with FSH-14 Hydraulic Wedge Spreader.



# A, WR-Series, Wedgie and Spread Cylinders

▼ Shown clockwise from top: WR-15, WR-5, A-92



- Single-acting, spring return
- WR-5 hydraulic wedgie cylinder: for use in very confined work areas
- WR-15 hydraulic spread cylinder: for long stroke spreading applications
- A-92, Spreader attachment: threads on 10 ton RC-Series DUO cylinders (except RC-101 \*).

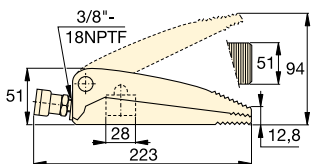

WR-5

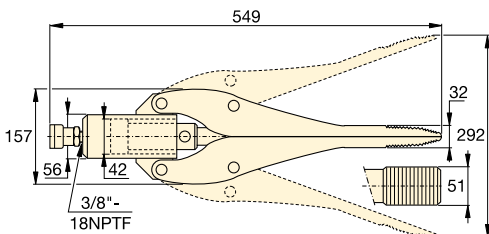

WR-15

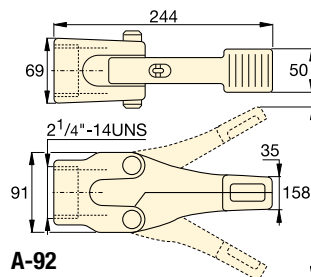

A-92

Cylinder Capacity	Tip Clearance	Model Number	Maximum Spread	Cylinder Effective Area	Oil Capacity	
ton (kN)	(mm)		(mm)	(cm <sup>2</sup> )	(cm <sup>3</sup> )	(kg)
1,0 (8,9)	12,8	WR-5	94	6,5	10	2,3
0,75 (6,0)	32,0	WR-15	292	14,5	64	11,3
1,0 (8,9)	35,0	A-92 *	158	–	–	3,6

\* Maximum system pressure must be limited to half the rated pressure (350 bar).

## A, WR Series

Capacity:

**0,75 - 1,0 ton**

Tip Clearance:

**12,8 - 35,0 mm**

Maximum Spread:

**94 - 292 mm**

Maximum Operating Pressure:

**700 bar**



### Power Box

Tool box with hand pump, gauge adaptor assembly, hose and RC-, RCS, RSM-Series cylinders, WR-5 or LW-16 cylinder.

Page: 61



### Best Match Hand Pump

To power your WR-5, WR-15 and A-92 Spreader attachment the P-392 Hand Pump is an ideal choice. See [www.enerpac.com](http://www.enerpac.com) or

the Enerpac Industrial Tools catalogue for the full range of hand pump options.

Page: 62

▼ A WR-5 hydraulic wedgie cylinder is used for maintenance on a bridge bearing.





# FF-Series, QuickFace – Mechanical Pipe Flange Face Tool

▼ Shown: FF-120



- Makes refacing easy – hand operated machine tool can be set up anywhere without the need for air, electric or hydraulic power
- Lightweight and portable (15 kg in storage box)
- Adjustable cutting head for reface of flat flange surfaces of pipes with flange OD facing range 25,4 - 304,8 mm [1 - 12 inch]
- Interchangeable collets for ID mounting range 25,4 - 152,4 mm [1-6 inch] allow the user to work on many different flanges with minimal time between set-ups
- Interchangeable lead screws suitable for refacing damaged raised-face (RF), flat-face (FF) or lens-ring joint flanges
- Tool body with expanding collets centers itself providing real concentric operation.

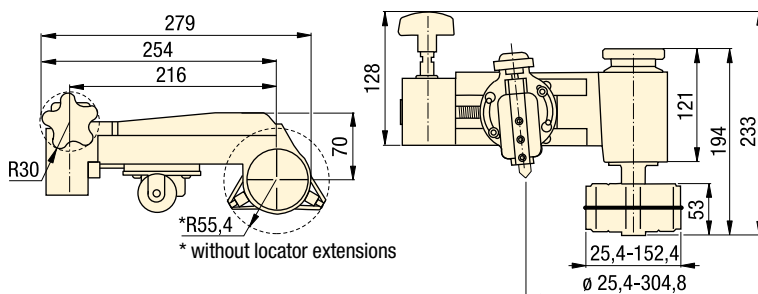

## ▼ SELECTION CHART

Pipe Flange Cutting Diameter Range		Internal Pipe Mounting Diameter Range		Cutting Resultant Roughness (Ra μ)	Model Number	 (kg)
(mm)	(inch)	(mm)	(inch)			
25,4 - 304,8	1,0 - 12,0	25,4 - 152,4	1,0 - 6,0	3,2 - 12,5	FF-120	6,8

## FF Series

Pipe Flange Cutting Diameter Range:

**ø 25 - 305 mm / 1 - 12"**

Internal Pipe Mounting Range:

**ø 25 - 152 mm / 1 - 6"**

Cutting Resultant Roughness:

**Ra 3,2 - 12,5 μ**



### Fine Thread Feed Screw

Fine Thread Feed Screw Accessory Kit **FF120FSF** is included as standard and provides a fine thread feed screw, 1/2"-20 UNF, and delivers a surface roughness of Ra 1,6 - 2,4 μ (60-100 micro inches).



### Joint Separation Tools

FS and FSH-Series parallel wedge spreaders provide quick and easy joint separation using hydraulic or mechanical force.

Page: 68



### Flange Alignment Tools

The ATM-Series provide safe and high-precision flange alignment tools that fit most commonly used ANSI, API, BS and DIN flanges.

Page: 64

▼ The Enerpac FF-120 QuickFace has same precision and quality of finish as a lathe.





## Enerpac 'Yellow Pages' stand for technical information!

If selecting bolting tools is not your daily routine, then you will appreciate these pages. The 'Yellow Pages' are designed to help you work with hydraulics. They will help you to better understand the basics of bolting system set-ups and of the most commonly used bolting techniques.

The better your choice of equipment, the better you will appreciate these tools. Take the time to go through these 'Yellow Pages' and you will benefit even more from Enerpac Bolting Solutions.



### Enerpac Warranty Statement

Visit our web site for the complete Global Lifetime Warranty or call your Authorized Service Center.

Section		Page
Safety Instructions		74 ▶
Bolting Theory		76 ▶
Torque Tightening		78 ▶
Tensioning		80 ▶
Hexagon Bolt and Nut Sizes		82 ▶
Key to measurement		83 ▶
Pressure versus Torque Charts S and W-Series Wrenches		84 ▶
Bolting Service & Safety		86 ▶
Enerpac Academy		87 ▶
About Enerpac		88 ▶

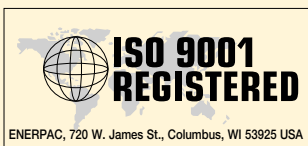

Enerpac is certified for several quality standards. These standards require compliance with standards for management, administration, product development and manufacturing. Enerpac worked hard to earn the quality rating ISO 9001, in its ongoing pursuit of excellence.

### ISO 1402, ISO 4672, ISO 6803

Enerpac thermoplastic hoses are related to the criteria set forth in these standards.



### ATEX 95 Certified

The ATP, ZA and XA-Series air pumps and S and W-Series torque wrenches are tested and certified according to the Directive 2014/34/EU "ATEX Directive". The explosion protection is for equipment group II, equipment category 2 (hazardous zone area 1), in gas and/or dust atmospheres. ATP, ZA and XA-Series air pumps are marked: Ex II 2 GD ck T4.

### Product Design Criteria

All hydraulic components are designed and tested to be safe for use at maximum 700 bar (10.000 psi) pressure unless otherwise specifically noted.



Where specified, Enerpac electric power units meet the design, assembly and test requirements of the Standards Council of Canada (CAN C22.2 No. 68-92), and UL73 for the United States. Units were tested and certified for both USA and Canada by TÜV and by CSA, national recognized testing laboratories.

### EMC Directive

Where specified, Enerpac electric power pumps meet the requirements for Electromagnetic Compatibility per EMC Directive 2004/108/EC.



### CE Marking & Conformity

Enerpac provides a Declaration of Conformity and CE marking for products that conform with the European Community Directives.

### ASME B30.1-2015

Our cylinders fully comply with the criteria set forth by the American National Standards Institute (except RD, BRD, CLL, CLP and CLS-Series).

# Bolting Solution and Application Worksheet



Please complete the following information prior contacting Enerpac for your bolting proposal:

Requested By: \_\_\_\_\_

Requested Date: \_\_\_\_\_

Company: \_\_\_\_\_

Industry: \_\_\_\_\_

Contact: \_\_\_\_\_

Title: \_\_\_\_\_

Phone: \_\_\_\_\_

Fax: \_\_\_\_\_

Email: \_\_\_\_\_

Description of Application (provide drawings if possible):

\_\_\_\_\_

\_\_\_\_\_

\_\_\_\_\_

Type of Application:

\_\_\_\_\_

\_\_\_\_\_

## APPLICATION TECHNICAL DATA

Bolt Quantity: \_\_\_\_\_

Bolt Diameter: \_\_\_\_\_

Bolt Threads per Inch/Pitch: \_\_\_\_\_

Bolt Grade: \_\_\_\_\_

Bolt Coating: \_\_\_\_\_

Gasket Type: \_\_\_\_\_

Appl. Operating Temperature, °C or °F: \_\_\_\_\_

### Known Bolting Values:

Load  
(kN / lbs) \_\_\_\_\_ % of Yield (N/mm<sup>2</sup> / psi)

Stretch-Bolt Length  
(mm / inch) \_\_\_\_\_

Turn of Nut  
(Preload / Degrees) \_\_\_\_\_

Torque  
(Nm / Kgm / Ft.lbs) \_\_\_\_\_

### Application Position:

Top-side

Vertical

Inverted

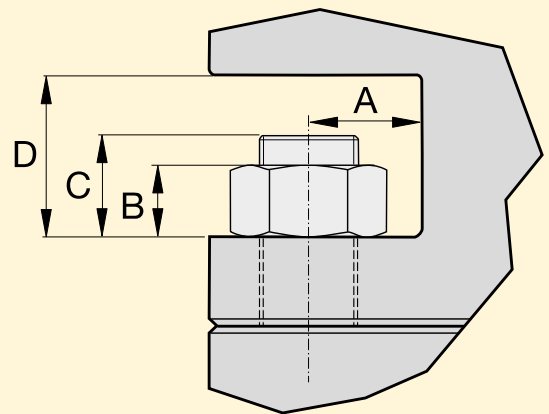
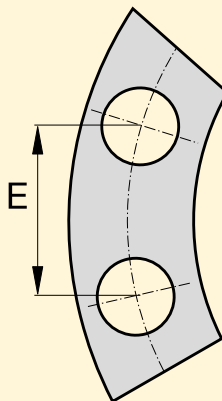

### Specify Dimensions:

INCH

MM (Metric)

A \_\_\_\_\_ B \_\_\_\_\_ C \_\_\_\_\_ D \_\_\_\_\_ E \_\_\_\_\_

Distance to Closure: \_\_\_\_\_

Current Lubrication: Type \_\_\_\_\_ Brand \_\_\_\_\_



# Safety Instructions



When used correctly, hydraulic power is one of the safest methods of applying force to your work. And to that end we offer some DO's and DON'Ts, simple common sense points which apply to practically all Enerpac hydraulic products.

- Lift slowly and check the load often
- Avoid standing in the line of force
- Anticipate possible problems and take steps to avoid them.

The line drawings and application photo's of Enerpac products throughout this catalog are used to portray how some of our customers have used hydraulics in industry.

In designing similar systems, care must be taken to select the proper components that provide safe operation and fit your needs.

Check to see if all safety measures have been taken to avoid the risk of injury and property damage from your application or system.

Enerpac can not be held responsible for damage or injury, caused by unsafe use, maintenance or application of its products.

Please contact the Enerpac office or a representative for guidance when you are in doubt as to the proper safety precautions to be taken in designing and setting up your particular system.

In addition to these tips, every Enerpac product comes with instructions spelling out specific safety information. Please read them carefully.

## Bolting Tools

		Always use the proper personal protection equipment (PPE).			Never stand in-line with the bolt axis.
		Always check your system set-up and follow the correct bolting procedures.			Never stand in-line with the flange or pipe opening.
		Never stand in-line with the pressure, couplers or hoses.			Never hold pressurized hoses.
		The torque wrench (or tool) operator is always in charge.			Hold torque wrench (or tool) at handle only. Do not place any part of body between wrench and reaction point.

## Cylinders

		Provide a solid support for the entire cylinder base area. Use cylinder base attachment for more stability.			As with jacks, never place any part of your body under the load. Load must be on cribbing before venturing under.
--	--	---	--	--	---



## General

**80%** Manufacturer's rating of load and stroke are maximum safe limits. **80%**  
**Good practice encourages using only 80% of these ratings!**

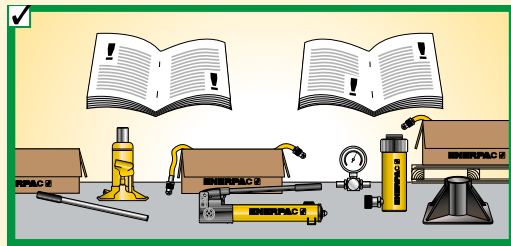

Always read instructions and safety warnings that come with your Enerpac hydraulic equipment.

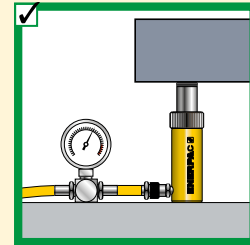
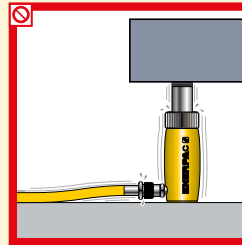

Don't override the factory setting of relief valves. Always use a gauge to check system pressure.

## Pumps

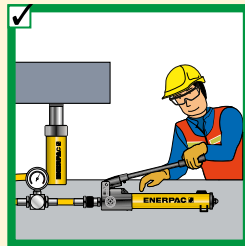
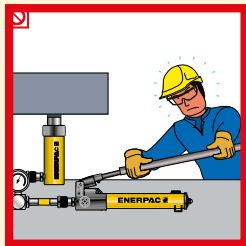

Don't use handle extenders. Hand pumps should be easy to operate when used correctly.

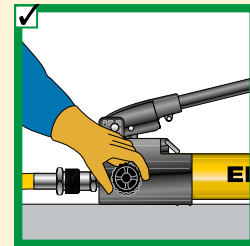
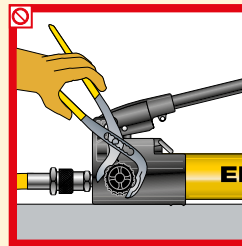

Close release valve finger tight. Using force will ruin the valve.

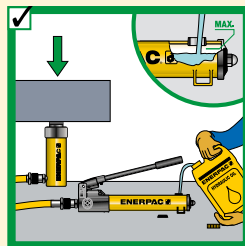
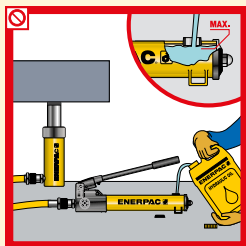

Fill pump only to recommended level. Fill only when connected cylinder is fully retracted.

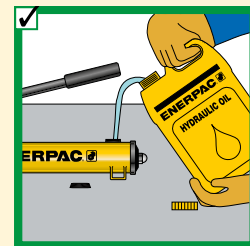
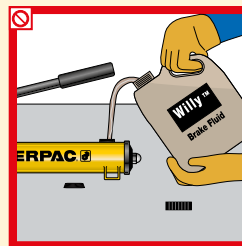

Use only genuine Enerpac hydraulic oil. Wrong fluid can destroy seals and pump and will render your warranty null and void your guarantee.

## Hoses and couplers

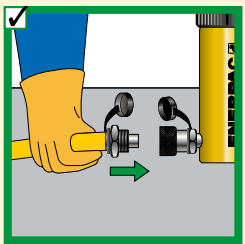
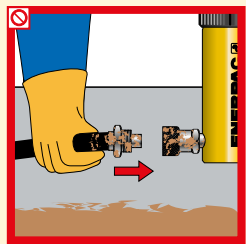

Clean both coupler parts before connecting. Use dust caps when coupler parts are not connected.

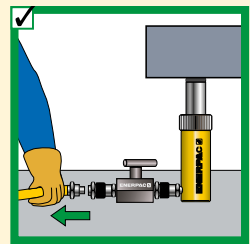
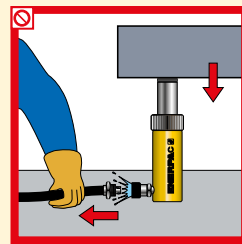

Detach cylinder only when fully retracted or use shut-off valves or safety valves to lock-in cylinder pressure.

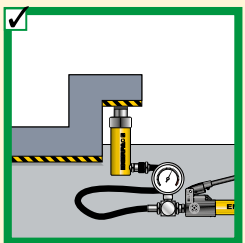
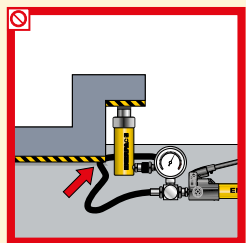

Keep hoses away from the area beneath loads.

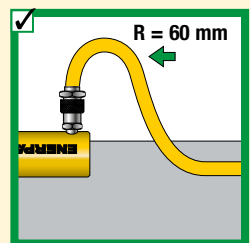
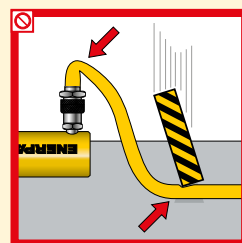

Don't kink hoses. Bending radius should be at least 60 millimetres. Don't drive over or drop heavy objects on hoses.

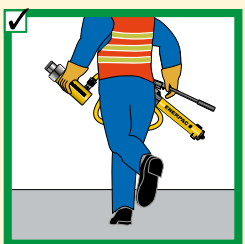

Don't lift hydraulic equipment by the hoses.

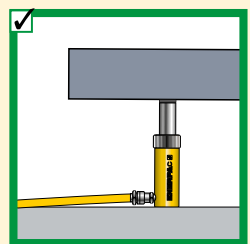
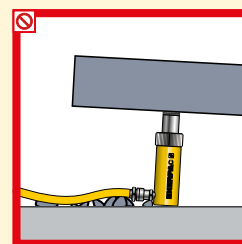

Never allow the cylinder to be lifted off the ground through the couplers.



## Function of Bolts and Nuts

Threaded fasteners are used across industry to assemble products ranging from pipelines to heavy-duty earth movers and from cranes to bridges and many more. Their principle function is to create a clamping force across the joint which is able to sustain the operating conditions without loosening.

Correctly tightened bolts make use of their elastic properties, to work well they must behave like springs. When load is applied, the bolt stretches and tries to return to its original length. This creates compressive force across the joint members.

## Hooke's Law of Physics

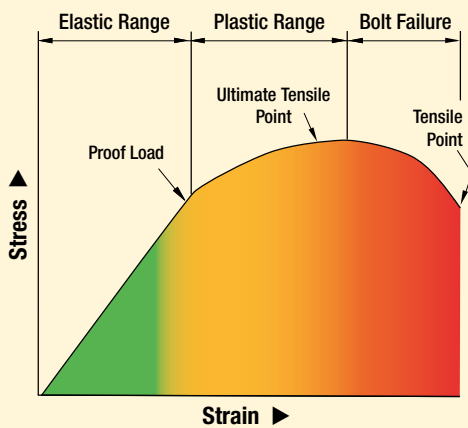

## Behavior of Bolts and Nuts

Elasticity is defined in Hooke's Law of physics: The stress in a bolt is directly proportional to its strain. The stress-strain of a bolt has an **elastic range** and a **plastic range**. In the elastic range Hooke's Law is true.

All of the elongation applied within the elastic range is relieved when the load is removed. The amount of elongation increases when more load is applied. When a bolt is stressed beyond its **proof load** (maximum load under which a bolt will behave in an elastic manner), the elastic elongation changes to plastic deformation and the strain will no longer be proportional to the stress.

In the plastic deformation a part of the elongation will remain after the load is removed. The point where this permanent elongation occurs is called the yield strength. The further application of load takes the bolt to a point where it begins to fail this is termed its **ultimate tensile strength (UTS)**. At this UTS-point, if additional force is applied to the bolt it will continue to elongate until it finally breaks. The point at which the bolt breaks is called the **tensile point**.

Careful attention must be paid to the grade of bolt being used as bolt grades differ in the elastic range.

## Uniform preload (residual load)

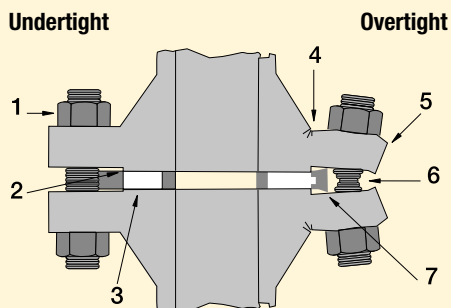

1. Bolt loosens due to cycle loads of vibration.
2. Sealing face surface damage.
3. No compression.
4. Cracking.
5. Flange rotation.
6. Yielding of bolts.
7. Over-compression of gasket

## Preload

The main purpose of a bolt and nut is to clamp parts together with the correct force to prevent loosening in operation. The term **preload** refers to the loading in a bolt immediately after it has been tightened.

The amount of preload (residual load) is critical as the joint can fail if the load in the bolt is too high, too low or not uniform in every bolt.

### Uneven bolt loads can result in:

- Some bolts being loose while others are overloaded.
- Crushing of the gasket on one side, leakage on the other side.

Preload is normally dictated by the joint design, (see Enerpac Bolted Joint Integrity) for information on common joint types or contact your local representative.



## Tightening Methods

Principally there are two modes of tightening: "Uncontrolled" and "Controlled".

### Uncontrolled tightening

Uses equipment and/or procedures that cannot be measured. Preload is applied to a bolt and nut assembly using a hammer and spanner or other types of impact tools.

### Controlled tightening

Employs calibrated and measurable equipment, follows prescribed procedures and is carried out by trained personnel. There are two main techniques: Torque tightening and Bolt tensioning.

### 1. Torque tightening

Achieves preload in a bolt and nut assembly via the nut in a controlled manner using a tool.

### 2. Bolt tensioning

Achieves preload in a bolt and nut assembly by stretching the bolt axially using a tool.

## Advantages of Controlled Tightening

### Known, controllable and accurate bolt loads

Employs tooling with controllable outputs and adopts calculation to determine the required tool settings.

### Uniformity of bolt loading

Especially important on gasketed joints as an even and consistent compression is required for the gasket to be effective.

### Safe operation following prescribed procedures

Eliminates the dangerous activities of manual uncontrolled tightening and requires that the operators be skilled and follow procedures.

### Reduces operational time resulting in increased productivity

Reduces tightening time and operator fatigue by replacing manual effort with the use of controlled tooling.

### Reliable and repeatable results

Using calibrated, tested equipment, following procedures and employing skilled operators achieves known results consistently.

### The right results first time

Many of the uncertainties surrounding in-service joint failures are removed by ensuring the correct assembly and tightening of the joint are carried out the first time.



### Bolting Integrity Software

A comprehensive on-line software solution for Bolted Joint Integrity.

Integral databases hold data for:

- BS1560, MSS SP44, API 6A and 17D flanged joints
- Common gasket materials and configurations
- Comprehensive range of bolt materials
- Comprehensive range of lubricants
- Enerpac's Controlled Bolting Equipment includes: Torque Multipliers, Hydraulic Wrenches and Bolt Tensioners.

Custom Joint information can also be entered.

The software offers Tool selection, Bolt Load calculations and Tool pressure settings, as well as, a combined Application data sheet and Joint completion report.

The screenshot displays the 'Torque Calculation' interface of the Enerpac software. It features a navigation bar with 'Calculations', 'Inquiries', 'Help', 'Contact Us', and 'Enerpac.com'. The main content area is divided into several sections:

- Calculation Information:** Includes fields for 'Tightening Method' (Torque/Tensioning), 'Nut/Nutset' (Standard/Insert), 'Pressure Units' (Psi/Barg), 'Lubricant', 'Locks', 'Standard', and 'Bolt Material'. It also has dropdown menus for 'Flange Size', 'Flange Class', 'Flange Material', 'Gasket', 'Joint Type', and 'Bolt Material'.
- Diagram:** A technical drawing of a flange joint with dimension lines.
- Diagram Values:** A table listing dimensions such as Bolt Hole Diameter, Flange OD, Bolt Circle Diameter, Total Flange Length, Flange Thickness, Weld Neck OD, and Pipe OD.
- Tightening Values:** A table showing Residual Stress, Bolt Load, and Torque.
- Selected Tool:** A section for tool selection, currently showing 'No Tool Selected'.
- Joint Data:** A table listing joint specifications like Joint Thickness, Gasket, Bolt, Min Bolt Length, and Bolt A/P.
- Material Properties:** A table showing Minimum To Seal, Yield Stress, Allowable Stress, % Residual Yield, Applied Stress, Applied Load, and % Applied Yield.

Visit [www.enerpac.com](http://www.enerpac.com) to access our free on-line bolting software application and obtain information on tool selection, bolt load calculations and tool pressure settings. A combined application data sheet and joint completion report is also available.



## Torque Tightening

Turning movement

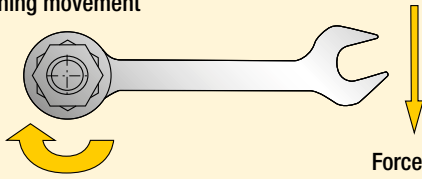

Stretch of Fastener (Pre-load)

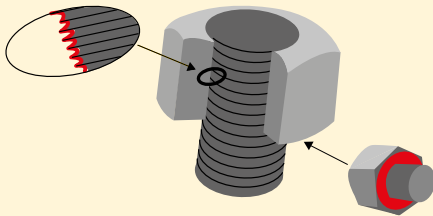
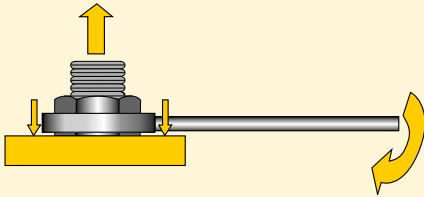

Friction points should always be lubricated when using the torque tightening method.

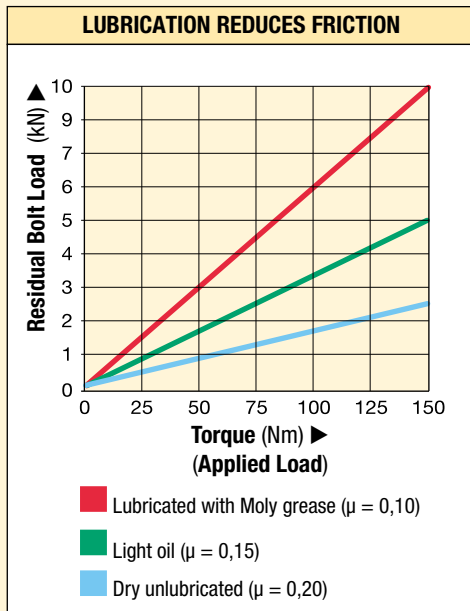

Example of how a lubricant can reduce the effect of friction and convert more torque to bolt preload.

## What is Torque?

It is a measure of how much force acting on an object which causes that object to rotate.

## What is Torque Tightening?

The application of preload to a fastener by the turning of the fastener's nut.

## Torque Tightening and Preload

The amount of preload created when torquing is largely dependant on the effects of friction.

Principally there are three different "torque components":

- torque to stretch the bolt
- torque to overcome the friction in bolt and nut threads
- torque to overcome friction at the nut spot face (bearing contact surface).



**Preload (residual load) = Applied Torque minus Frictional Losses**

## Lubrication Reduces Friction

Lubrication reduces the friction during tightening, decreases bolt failure during installation and increases bolt service life. Variation in friction coefficients affect the amount of preload achieved at a specified torque. Higher friction results in less conversion of torque to preload.

The value for the friction coefficient provided by the lubricant manufacturer must be known to accurately establish the required torque value. Lubricant or anti-seizure compounds should be applied to both the nut bearing surface and the male threads.

## Frictional Losses

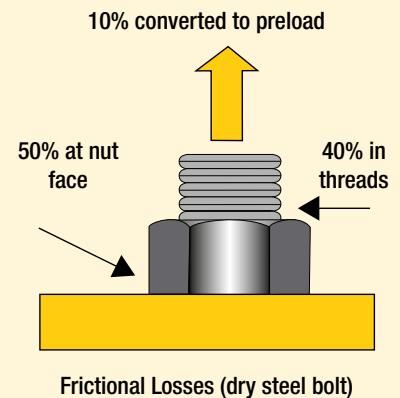





**80%** Manufacturer's rating of pressure and torque are maximum safe limits. **80%**  
 Good practice encourages using only 80% of these ratings!

## Torque Procedure

When torquing it is common to tighten only one bolt at a time, this can result in Point Loading and Load Scatter. To avoid this, torque is applied in stages following a prescribed pattern:

## Torque Sequence

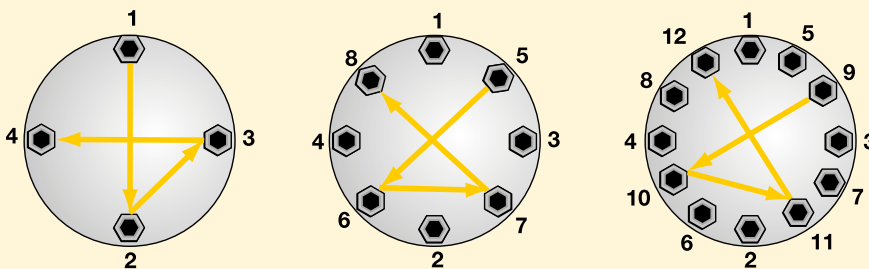

- Step 1** Spanner tight ensuring that 2 - 3 threads extend above nut
- Step 2** Tighten each bolt to one-third ( $\frac{1}{3}$ ) of the final required torque following the pattern as shown above.
- Step 3** Increase the torque to two-thirds ( $\frac{2}{3}$ ) following the pattern shown above.

- Step 4** Increase the torque to full torque following the pattern shown above.
- Step 5** Perform one final pass on each bolt working clockwise from bolt 1, at the full final torque.



### Select the Right Wrench

Choose your Enerpac torque wrench using the untightening rule of thumb:

- When loosening a nut or bolt more torque is usually required than when tightening.
- For general conditions it can take up to **2½ times** the input torque to breakout.
- Do not apply more than 75% of the maximum torque output of the tool when loosening nuts or bolts.

### Conditions of bolted joints

- Humidity corrosion (rust) requires up to **2 times** the torque required for tightening.
- Sea water and chemical corrosion requires up to **2½ times** the torque required for tightening.
- Heat corrosion requires up to **3 times** the torque required for tightening.

### Minimum Output Torque

- The recommended minimum torque value of a hydraulic wrench is 10% of the maximum rated value.



### Breakout Torque

When loosening bolts a torque value higher than the tightening torque is normally required. This is mainly due to corrosion and deformations in the bolt and nut threads.

Breakout torque cannot be accurately calculated, however, depending on conditions it can take up to **2½ times** the input torque to breakout.

The use of penetrating oils or anti-seize products is always recommended when performing breakout operations.



# Tensioning

## Tensioning requires longer bolts



**INCORRECT**

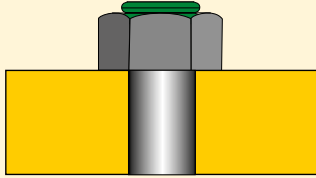

**CORRECT**

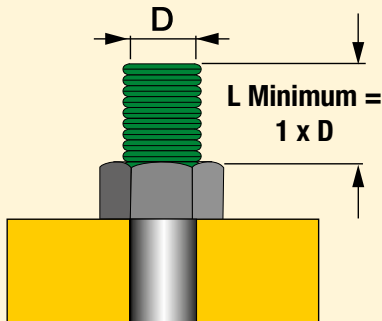

## What is Bolt Tensioning?

Tensioning is the direct axial stretching of the bolt to achieve preload. Inaccuracies created through friction are eliminated. Massive mechanical effort to create torque is replaced with simple hydraulic pressure. A uniform load can be applied by tensioning multiple studs simultaneously.

Tensioning requires longer bolts, and a seating area on the assembly around the nut. Tensioning can be done using detachable Bolt Tensioners or Hydraulic Nuts.



**Preload (residual load) = Applied Load minus Load Losses**

## What is Load Loss?

Load loss is a loss of bolt elongation depending on factors such as thread deflections, radial expansion of the nut, and embedding of the nut into the contact area of the joint. Load loss is accounted for in calculation and is added to the preload value to determine the initial **Applied Load**.

**The preload depends on Applied Load and Load Loss (load loss factor).**



## GLOSSARY OF TERMS

### Applied Load:

The load applied to a bolt during tensioning which includes an allowance for Load Loss.

### Bolt Tensioning:

A method of controlled tightening which applies preload to a bolt by stretching it axially.

### Breakout Torque:

The amount of torque required to loosen a tightened bolt. (Usually more torque is required to loosen a bolt than was used to tighten it.)

### Elastic Range:

The range on a bolt's stress / strain curve where stress is directionally proportional to strain.

### Plastic Range:

The range on a stress / strain curve where the tensile load applied to a bolt results in permanent deformation.

### Load Loss:

The losses in a bolt which occur on transfer of load from a tensioning device to the bolt assembly (these may arise from phenomena such as thread deflection and embedding of the nut to the contact area of the joint, and is calculated as a factor of the length to diameter ratio of the bolt).

### Load Scatter:

The spread of differing loads in a sequence of bolts after they have been loaded. It is mostly due to the elastic interaction of the bolts and the joint member; as subsequently tightened bolts further compress the joint, previously tightened bolts are subject to some relaxation.

### Preload:

The load in a bolt immediately after it has been tightened.

### Proof Load:

Proof load is often used interchangeably with Yield Strength but is usually measured at 0,2% plastic strain.

### Tensile Point:

The point at which the tensile loading on a bolt causes the bolt to rupture.

### Torque Tightening:

The application of Preload to a bolt by turning of the bolt's nut.

### Ultimate Strength:

The maximum tension which can be created by tensile load on a bolt.

### Yield Strength:

The point at which a bolt begins to plastically deform under tensile loading.

NOTE: Bolt is used as a generic term for a threaded fastener.



**80%** **Manufacturer's rating of pressure and load are maximum safe limits. Good practice encourages using only 80% of these ratings!** **80%**

## Tensioning Operation

Tensioning permits the simultaneous tightening of multiple bolts; the tools are connected in sequence via a high-pressure hose assembly to a single pump unit. This ensures each tool develops the exact same load and

provides a uniform clamping force across the joint. This is especially important for pressure containing vessels requiring even gasket compression to affect a seal.

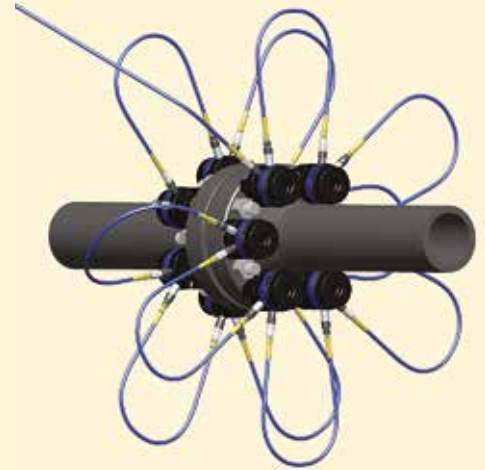

### Set-up using a 100% tensioning procedure

All bolts are tensioned simultaneously.

## General Procedure

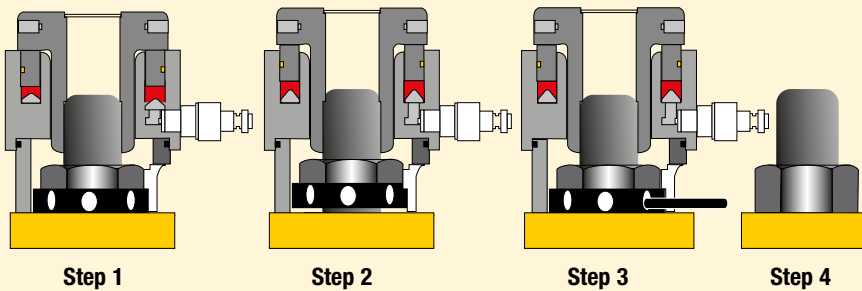

- Step 1:** The bolt tensioner is fitted over the stud.
- Step 2:** Hydraulic pressure is applied to the tensioner which then stretches the stud (bolt).
- Step 3:** The stud's nut is wound down against the joint face
- Step 4:** Hydraulic pressure is released and the tensioner removed.

The bolt behaves like a spring, when the hydraulic pressure is released the bolt is under tension and attempts to contract, creating the required clamping force across the joint.

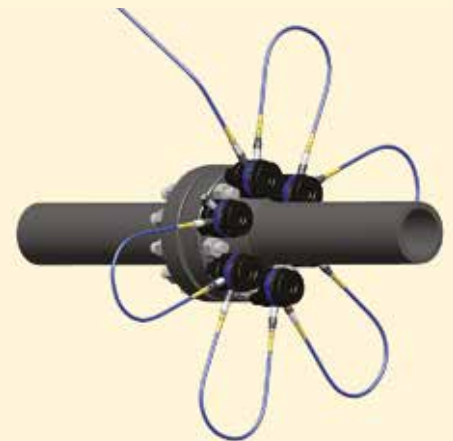

### Set-up using a 50% tensioning procedure

Half the bolts are tensioned simultaneously, the tools are relocated on the remaining bolts and they are subsequently tensioned.

## Less than 100% Tensioning

Not all applications allow for the simultaneous fit of a tensioning device on each bolt, in these cases at least two tensioning pressures are applied. This is to account for a load loss in those bolts already tensioned as the next sets are tightened.

The load losses are accounted for in calculation and a higher load is applied to allow the first sets to relax back to the target preload.



### Read Instruction Manuals

Please refer to the product Instruction Sheets for safe use guidelines and detail on the correct set up and operation of the equipment.



# Hexagon Nut and Bolt Sizes

## METRIC SIZES

Thread Size D (mm)	Hexagon Size S (mm)	Hexagon Size J (mm)
M10	17	8
M12	19	10
M14	22	12
M16	24	14
M18	27	14
M20	30	17
M22	32	17
M24	36	19
M27	41	19
M30	46	22
M33	50	24
M36	55	27
M39	60	27 (30)
M42	65	32
M45	70	-
M48	75	36
M52	80	36
M56	85	41
M60	90	46
M64	95	46
M68	100	50
M72	105	55
M76	110	60
M80	115	65
M85	120	70
M90	130	70 (75)
M95	135	-
M100	145	85
M105	150	-
M110	155	-
M115	165	-
M120	170	-
M125	180	-
M130	185	-
M140	200	-
M150	210	-

## IMPERIAL SIZES

Thread Size D (inch)	Hexagon Size * S (inch)	Hexagon Size J (inch)
5/8	1 1/16	1/2
3/4	1 1/4	5/8
7/8	1 7/16	3/4
1	1 5/8	3/4
1 1/8	1 13/16	7/8
1 1/4	2	7/8
1 3/8	2 3/16	1
1 1/2	2 3/8	1
1 5/8	2 9/16	-
1 3/4	2 3/4	1 1/4
1 7/8	2 15/16	1 3/8
2	3 1/8	1 5/8
2 1/4	3 1/2	1 3/4
2 1/2	3 7/8	1 7/8
2 3/4	4 1/4	2
3	4 5/8	2 1/4
3 1/4	5	2 1/4
3 3/4	5 3/4	2 1/4

\* Heavy hexagon nuts.



Determine the maximum torque according to the bolt (nut) size and grade. Always consult the manufacturers instructions or engineering recommendations when making bolted connections.



### IMPORTANT

The hexagon sizes shown in the tables should be used as a guide only. Individual sizes should be checked before specifying any equipment.



### BSH-Series Sockets

Use only Heavy Duty Impact Sockets for power driven torquing equipment, according to ISO2725 and ISO1174;

DIN3129 and DIN3121 or ASME-B107.2/1995.



## Key to measurements

All capacities and measurements in the catalog are expressed in uniform values. The conversion chart provides helpful information for their translation into equivalent systems.

FDM Conversion Chart		
Inches	Decimal	mm
1/16	0,06	1,59
1/8	0,13	3,18
3/16	0,19	4,76
1/4	0,25	6,35
5/16	0,31	7,94
3/8	0,38	9,53
7/16	0,44	11,11
1/2	0,50	12,70
9/16	0,56	14,29
5/8	0,63	15,88
11/16	0,69	17,46
3/4	0,75	19,05
13/16	0,81	20,64
7/8	0,88	22,23
15/16	0,94	23,81
1	1,00	25,40

## Pressure:

1 psi	= 0,069 bar
1 bar	= 14,50 psi
	= 10 N/cm <sup>2</sup>
1 kPa	= 0,145 psi
1 MPa	= 145 psi

## Force:

1 lbf	= 4,45 N
1 klbf	= 1000 lbf
1 kN	= 1000 N

## Weight:

1 pound (lb)	= 0,4536 kg
1 kg	= 2,205 lbs
1 metric ton	= 2205 lbs
	= 1000 kg
1 ton (short)	= 2000 lbs
	= 907,18 kg

## Temperature:

To Convert °C to °F:  
 $T^{\circ}\text{F} = (T^{\circ}\text{C} \times 1,8) + 32$

To Convert °F to °C:  
 $T^{\circ}\text{C} = (T^{\circ}\text{F} - 32) \div 1,8$

## Volume:

1 in <sup>3</sup>	= 16,387 cm <sup>3</sup>
1 cm <sup>3</sup>	= 0,061 in <sup>3</sup>
1 liter	= 61,02 in <sup>3</sup>
	= 0,264 gal
1 US gal	= 3,785 cm <sup>3</sup>
	= 3,785 l
	= 231 in <sup>3</sup>

## Other measurements:

1 inch	= 25,4 mm
1 mm	= 0,039 in
1 ft	= 0,3048 m
1 m	= 3,2808 ft
1 in <sup>2</sup>	= 6,452 cm <sup>2</sup>
1 cm <sup>2</sup>	= 0,155 in <sup>2</sup>
1 hp	= 0,746 kW
1 kW	= 1,340 hp
1 Nm	= 0,738 Ft.lbs
1 Ft.lbs	= 1,356 Nm
1 kN	= 224,82 lbs



### Free Conversion Calculator

Visit [enerpac.com](http://enerpac.com) and download the free conversion calculator.

## Torque Conversion Factors

Units to be converted	International System - S.I. (Nm)	Imperial (Lbf.ft)	Metric (kgf.m)
1 Ft.lbs	1,356	1,000	0,138
1 Nm	1,000	0,738	0,102
1 kgf.m	9,807	7,233	1,000



### Pressure versus Torque

See the pressure versus torque charts for S and W-Series hydraulic torque wrenches.



# Pressure versus Torque S-Series



**Pressure versus Torque – S-Series Torque Wrenches**

Pump Pressure (bar)	S1500X	S3000X	S6000X	S11000X	S25000X
	Torque Output (T <sub>F</sub> = 2,83) (Nm)	Torque Output (T <sub>F</sub> = 6,34) (Nm)	Torque Output (T <sub>F</sub> = 12,08) (Nm)	Torque Output (T <sub>F</sub> = 21,96) (Nm)	Torque Output (T <sub>F</sub> = 49,42) (Nm)
69	195	437	834	1515	3410
83	235	526	1003	1823	4102
97	274	615	1172	2130	4794
110	311	697	1329	2415	5436
124	351	786	1498	2723	6128
138	390	875	1668	3030	6820
152	430	963	1837	3338	7512
166	470	1052	2006	3645	8203
179	506	1134	2163	3931	8846
193	546	1223	2332	4238	9538
207	586	1312	2501	4545	10.230
221	625	1400	2671	4853	10.922
234	662	1483	2828	5138	11.564
248	702	1572	2997	5446	12.256
262	741	1660	3166	5753	12.948
276	781	1749	3335	6061	13.640
290	821	1838	3504	6368	14.331
303	857	1920	3662	6653	14.974
317	897	2009	3831	6961	15.666
331	937	2098	4000	7268	16.358
345	976	2186	4169	7576	17.049
359	1016	2275	4338	7883	17.741
372	1053	2357	4495	8169	18.384
386	1092	2446	4665	8476	19.076
400	1132	2535	4834	8783	19.767
414	1171	2624	5003	9091	20.459
428	1211	2712	5172	9398	21.151
441	1248	2795	5329	9684	21.794
455	1287	2883	5498	9991	22.485
469	1327	2972	5668	10.298	23.177
483	1367	3061	5837	10.606	23.869
497	1406	3149	6006	10.913	24.561
510	1443	3232	6163	11.199	25.203
524	1483	3321	6332	11.506	25.895
538	1522	3409	6501	11.814	26.587
552	1562	3498	6671	12.121	27.279
566	1602	3587	6840	12.428	27.971
579	1638	3669	6997	12.714	28.613
593	1678	3758	7166	13.021	29.305
607	1718	3847	7335	13.329	29.997
621	1757	3935	7504	13.636	30.689
634	1794	4018	7662	13.922	31.331
648	1834	4106	7831	14.229	32.023
662	1873	4195	8000	14.536	32.715
676	1913	4284	8169	14.844	33.407
690	1952	4373	8338	15.151	35.455



### Convert pressure into torque

The function of a hydraulic torque wrench, is to convert hydraulic pressure into torque. This chart is a “quick-reference” to help in determining what this conversion factor is.

If you do not find your torque and pressure values in the chart, then the following conversion formulas can be used to find your theoretical torque value.

The actual value may vary due to wrench condition and age.

$$T = P \times T_F$$

$$P = T \div T_F$$

Where: **T** = target torque  
**P** = pressure  
**T<sub>F</sub>** = theoretical applied torque



### Bolting Integrity Software

A comprehensive on-line software solution for Bolted Joint Integrity.

Integral databases hold data for:

- BS1560, MSS SP44, API 6A and 17D flanged joints
- Common gasket materials and configurations
- Comprehensive range of bolt materials
- Comprehensive range of lubricants
- Enerpac's Controlled Bolting Equipment includes: Torque Multipliers, Hydraulic Wrenches and Bolt Tensioners

Custom Joint information can also be entered.

The software offers Tool selection, Bolt Load calculations and Tool pressure settings, as well as, a combined Application data sheet and Joint completion report.

# Pressure versus Torque W-Series



Pressure versus Torque – W-Series Torque Wrenches						
Pump Pressure	W2000X	W4000X	W8000X	W15000X	W22000X	W35000X
(bar)	Torque Output ( $T_F = 4,01$ ) (Nm)	Torque Output ( $T_F = 8,20$ ) (Nm)	Torque Output ( $T_F = 16,64$ ) (Nm)	Torque Output ( $T_F = 30,12$ ) (Nm)	Torque Output ( $T_F = 44,21$ ) (Nm)	Torque Output ( $T_F = 68,77$ ) (Nm)
69	277	566	1148	2078	3051	4745
83	333	681	1381	2500	3670	5708
97	389	796	1614	2922	4289	6671
110	441	902	1831	3314	4864	7565
124	497	1017	2064	3735	5483	8528
138	553	1132	2297	4157	6102	9491
152	609	1247	2530	4579	6721	10.453
166	665	1362	2763	5000	7340	11.416
179	718	1468	2979	5392	7915	12.310
193	774	1583	3212	5814	8534	13.273
207	830	1698	3445	6235	9153	14.236
221	886	1813	3678	6657	9772	15.199
234	938	1920	3894	7049	10.347	16.093
248	994	2035	4128	7470	10.996	17.055
262	1050	2149	4361	7892	11.585	18.018
276	1106	2264	4594	8314	12.204	18.981
290	1162	2379	4827	8736	12.823	19.944
303	1215	2486	5043	9127	13.398	20.838
317	1271	2601	5276	9549	14.017	21.801
331	1327	2715	5509	9971	14.636	22.764
345	1383	2830	5742	10.392	15.255	23.726
359	1439	2945	5975	10.814	15.874	24.689
372	1491	3052	6191	11.206	16.449	25.583
386	1547	3167	6424	11.627	17.068	26.546
400	1603	3281	6657	12.049	17.687	27.509
414	1660	3396	6890	12.471	18.306	28.472
428	1716	3511	7123	12.893	18.925	29.434
441	1768	3618	7340	13.284	19.500	30.328
455	1824	3733	7573	13.706	20.119	31.291
469	1880	3848	7806	14.128	20.738	32.254
483	1936	3962	8039	14.549	21.357	33.217
497	1992	4077	8272	14.971	21.976	34.180
510	2044	4184	8488	15.363	22.551	35.074
524	2100	4299	8721	15.784	23.170	36.037
538	2157	4414	8954	16.206	23.789	36.999
552	2213	4528	9187	16.628	24.408	37.962
566	2269	4643	9420	17.049	25.027	38.925
579	2321	4750	9636	17.441	25.602	39.819
593	2377	4865	9869	17.863	26.221	40.782
607	2433	4980	10.102	18.285	26.840	41.745
621	2489	5094	10.335	18.706	27.459	42.707
634	2541	5201	10.552	19.098	28.034	43.601
648	2598	5316	10.785	19.520	28.653	44.654
662	2654	5431	11.018	19.941	29.272	45.527
676	2710	5546	11.251	20.363	29.891	46.490
690	2766	5661	11.484	20.785	30.506	47.454



## Convert pressure into torque

The function of a hydraulic torque wrench, is to convert hydraulic pressure into torque.

This chart is a “quick-reference” to help in determining what this conversion factor is.

If you do not find your torque and pressure values in the chart, then the following conversion formulas can be used to find your theoretical torque value.

The actual value may vary due to wrench condition and age.

$$T = P \times T_F$$

$$P = T \div T_F$$

Where: T = target torque

P = pressure

$T_F$  = theoretical applied torque



## Bolting Integrity Software

A comprehensive on-line software solution for Bolted Joint Integrity.

Integral databases hold data for:

- BS1560, MSS SP44, API 6A and 17D flanged joints
- Common gasket materials and configurations
- Comprehensive range of bolt materials
- Comprehensive range of lubricants
- Enerpac's Controlled Bolting Equipment includes: Torque Multipliers, Hydraulic Wrenches and Bolt Tensioners

Custom Joint information can also be entered.

The software offers Tool selection, Bolt Load calculations and Tool pressure settings, as well as, a combined Application data sheet and Joint completion report.



## Enerpac Bolting Service

Offering full bolting tool service and maintenance wherever you need it. We provide you with personalized bolting demonstrations and training,

and the bolting service vehicle is equipped to perform torque wrench and other equipment calibrations and repairs on site.

We can give you advice on the best solutions and the bolting tools that are most suited to your application, thus enabling safe and controlled performance of your bolting activities.

- On-site demonstrations of Enerpac bolting tools
- Repair and calibration services
- Training for the safe and efficient use of Enerpac bolting tools

## Schedule a Bolting Service Demonstration

Use the distributor search at [enerpac.com](http://enerpac.com) to find the nearest Enerpac bolting service van to schedule a demonstration. These distributors display the bolting service icon.



## At Enerpac, we are committed to safety

Unfortunately, serious incidents can happen on a job site. Nevertheless, such mishaps may be avoidable if workers pay attention to the hazards and potential

risks, and know how to use tools correctly. Whether you work in maintenance or production, power plant, shipyard, mine, shop floor or construction site; learning to use hydraulic tools safely is mandatory.

Our Goal Zero initiative is part of our global commitment to improve workplace safety. We are committed to achieve the Goal of Zero harm to customers and end-users of our products.

## Worldwide Catalogue Coverage

Enerpac Catalogues are printed in many languages. If your requirements call for product use in a different country, please send your request to the applicable country listed on [www.enerpac.com](http://www.enerpac.com) – the Enerpac catalogue of the country serving your specific market area will be forwarded promptly.



WCC2015



9355



E328e



E215e



## WCC2015 The World Class Collection brochure

16 page brochure provides a selection of the most popular Enerpac industrial tools and solutions, collected from all categories.

## 9355 Integrated Solutions Capability Brochure

Enerpac's "Integrated Solutions" provides Heavy Lifting solutions to meet customer requirements for safe, precise control of movement and positioning of heavy loads.

## E328e Industrial Tools Catalogue

This 280 pages catalogue contains our full line of cylinders, pumps, presses, pullers, tools, valves and system components, bolting solutions and integrated solutions.

## E215e Workholding Catalogue

Offers innovative products and solutions to provide powerful clamping and positioning force to every type of manufacturing process. Workholding solutions increase product quality and production output.





Do you work with high-pressure hydraulic tools regularly or even every day? Operating such tools requires sound knowledge of how they work and this should be maintained.

**Effective use of these tools boosts safety and reduces risk - both for you as the operator and for the environment within which the tools are used. Having the right training will enable you to use the tools safely and properly.**

Enerpac Academy is our in-house training centre, set up exclusively for Enerpac business partners, Enerpac users and Enerpac employees: training programs ranging from tool expertise, repairs and maintenance, to safe operation of high-pressure hydraulic tools.

### **Putting theory into practice**

The training courses are interactive and benefit from a highly diverse program that puts the covered theory into practice right away. Our training services are grounded in many years of experience in providing and applying Enerpac tools.

### **Tailored training**

Enerpac Academy offers you the exclusive opportunity to train your (new) employees in making proper use of Enerpac tools. Our trainings can also be done on-site.

### **Safety training**

Safe use of Enerpac high pressure hydraulic tools, user and environmental safety.

### **Controlled bolting trainings**

Bolting tool theory, tool applications, hands-on training on safe and efficient use of torque wrenches, tensioners and pumps.

### **General hydraulic sales training**

Knowledge of hydraulics, hydraulic tools and applications. Tool repair training: Repair and maintenance of general Enerpac tools.

### **Application training**

Tool feature and benefits, tool application review, safe use of hydraulic tools and market information.



### **Enerpac Academy – The Power of Knowledge**

- Specialist in-house Enerpac training center
- Standard and tailored training programs
- Highly experienced trainers
- Selection of training courses with a proven (value adding) track record
- Knowledge and experience sharing
- User and tool safety come first.

### **EMP – Enerpac Maintenance Program**

EMP is a preventive maintenance program. Your Enerpac Authorised Service Centre will check the tools on essential points: leaking, oil level and quality, maximum pressure setting, and damage. EMP reduces operational risks, increases safety and minimises extremely expensive delays in your operations. You will be advised about regular maintenance of the Enerpac tools.

- Work more safely
- Minimise operational risk
- Ensure tools are always available and in tip-top shape
- As good as new after repair
- Prevent downtime
- Advice on safe and effective use
- Maintenance when tools are not used.

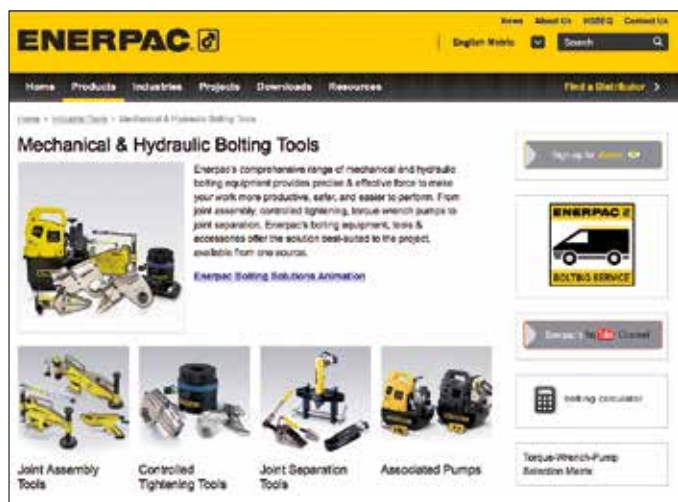

**Enerpac is the leading global provider of high-pressure hydraulic tools and solutions with a broad range of products, local expertise and worldwide distribution network. With a proven track record in a wide range of markets, Enerpac designs and manufactures high-quality tools and solutions for all industrial applications.**

Enerpac has gained unique experience in delivering hydraulic solutions for the controlled movement and positioning of heavy objects. Enerpac supports your business by offering the right solutions and service to help you get your work done efficiently and safely.

## Torque Calculation Engine

Enerpac's Bolting Calculator is our free web-based calculator designed to technically support our products. The software will calculate as well as recommend bolt load/stresses for your bolted applications. You may choose between torque or tension as your tightening method and all calculations include hydraulic tool pressures based on tool selection.

## Calculation Features

ANSI B16.5 & B16.47 Flanges  
API 6A & 17D Flanges  
Custom Calculations

## Customer Support Features

Access to Technical Documents  
Engineering Inquiry Section  
Procedures and Guidance

Log on to the bolting calculator at [www.enerpac.com](http://www.enerpac.com)

## [www.enerpac.com](http://www.enerpac.com) for latest Enerpac information

- Online Bolting Calculator
- Learn more about hydraulics
- Promotions
- New products
- Electronic Catalogues
- Trade shows
- Manuals (instruction and repair sheets)
- Nearest Distributors & Service Centers
- Enerpac products in action
- Integrated Solutions - Heavy Lifting

## Ordering Products and Catalogues

To find the name of the closest Enerpac distributor or service center, to request literature or technical application assistance, contact Enerpac at one of the addresses on the next page or pose your question through E-mail:

[info@enerpac.com](mailto:info@enerpac.com)

While every care has been taken in the preparation of this catalogue and all data contained within is deemed accurate at the time of printing, Enerpac does reserve the right to make changes to the specifications of any product, or discontinue any product, contained within this catalogue without prior notice.

All illustrations, performance specifications, weights and dimensions reflect the nominal values and slight variations may occur due to manufacturing tolerances.

Please consult Enerpac if final dimensions are critical. All information in this catalogue can be changed due to product improvements without prior notice.

© Copyright 2016, Enerpac.

**All rights reserved. Any copying or other use of material in this catalogue (text, illustrations, drawings, photo's) without express written consent is prohibited.**

# Model Number Index & Enerpac Worldwide Locations

<b>A</b>	Page:	<b>G</b>	Page:	<b>R</b>	Page:	<b>W</b>	Page:
A	70	GA	63, 67	RAH	28-29	W	12-25, 40, 85
AOT	7	GA45	61	RAT	38	WCR	24
ATM	64	GF	63	RC	61, 62	W-CS	24
ATP	60	GP	63, 67	RCS	61	WTE	25
		GT	56-57	RSM	61	WR	70
		GT4015	41, 43, 50, 52	RTE	9	WRP	25
						W-SL	22-23
<b>B</b>		<b>H</b>		<b>S</b>		<b>X</b>	
B, BH	59	HC	63, 67	S	6-7, 40, 84	XA	63, 67
BLT	38	HPT	59	SB	69	XC	63
BSH	10	HT	59	SBZ	45, 55		
BW	59	HR	32-33	SC	61, 63		
		HXD	30-33, 40	SDA	8	<b>Z</b>	
<b>C</b>		<b>I</b>		SLR	38	ZA	40, 52-55
CC	32-33	IN	32-33	SLW	61	ZE	40, 46-47
CFF	55			SRA	8	ZHE	45
CM	67	<b>L</b>		SRAT	38	ZRC	45, 55
CMF	55	LW	61	SRS	9, 61	ZTM	45, 55
				STF	68, 69	ZUTP	58
<b>D</b>		<b>N</b>		STN	65	ZU4T	40, 42-45
DSA	38	NC	65	SQD	26-29, 40		
		NS	66-67	SWH	12, 22	<b>00</b>	
<b>E</b>		<b>P</b>		SWR	61	25A	28-29
E	4-5	P	63, 65, 67-69			50A	28-29
ED, ER	38	PME, PMU	40, 41	<b>T</b>		75A	28-29
ETW	36-39	PTA	40, 50-51	THC	40	100A	28-29
		PTW	34-39	THQ	40	160A	28-29
<b>F</b>		PUD	67	TR	53	270A	28-29
FF	69			TSP	6, 9, 12, 25		
FRL	34-35			TQ	38, 46-47		
FS	66						
FSB, FSH, FSM	67						

## Australia and New Zealand

Actuant Australia Ltd.  
P.O. Box 6867, Wetherill Park, NSW 1851  
Block V Unit 3, Regents Park Estate  
391 Park Road, Regents Park NSW 2143  
Australia  
Tel: +61 287 177 200  
Fax: +61 297 438 648  
sales-au@enerpac.com

## Brazil

Power Packer do Brasil Ltda.  
Rua Luiz Lawrie Reid, 548  
09930-760 - Diadema (SP)-Brasil  
T +55 11 5687 2211  
Toll Free: 0800 891 5770  
vendabrasil@enerpac.com

## China (Taicang)

Actuant (China) Industries Co.Ltd.  
No. 6 Nanjing East Road,  
Taicang Economic Dep Zone  
Jiangsu, China  
T +86 0512 5328 7500  
F +86 0512 5335 9690  
Toll Free:  
T +86 400 885 0369  
sales-cn@enerpac.com

## Enerpac Integrated Solutions B.V.

Opaaistraat 44, 7554 TS Hengelo  
P.O. Box 421, 7550 AK Hengelo  
The Netherlands  
T +31 74 242 20 45  
F +31 74 243 03 38  
integratedsolutions@enerpac.com

## France, Switzerland, North Africa and French speaking African countries

ENERPAC  
Une division d'ACTUANT France S.A.S.  
Zone Orlytech, Bâtiment 516,  
1 allée du commandant Mouchotte CS 40351  
91550 Paray-Vieille-Poste, France  
T +33 1 60 13 68 68  
F +33 1 69 20 37 50  
sales-fr@enerpac.com

## Germany and Austria

Actuant GmbH  
P.O. Box 300113, D-40401 Düsseldorf  
Willstätterstrasse 13, D-40549 Düsseldorf  
Germany  
T +49 211 471 490  
F +49 211 471 49 28  
sales-de@enerpac.com

## India

Actuant India Private Limited  
No. 10, Bellary Road, Sadashivanagar,  
Bangalore - 560 080 India  
T +91 80 3928 9000  
info@enerpac.co.in

## Italy

ENERPAC S.p.A.  
Via Canova 4, 20094 Corsico (Milano)  
T +39 02 4861 111  
F +39 02 4860 1288  
sales-it@enerpac.com

## Japan

Applied Power Japan LTD KK  
Besshocho 85-7  
Kita-ku, Saitama-shi 331-0821, Japan  
T +81 48 662 4911  
F +81 48 662 4955  
sales-jp@enerpac.com

## Middle East, Egypt and Libya

ENERPAC Middle East FZE  
Plot M00737m 1242nd Street  
Jebel Ali Free Zone North  
P.O. Box 18004, Dubai  
United Arab Emirates  
T +971 (0)4 8872686  
F +971 (0)4 8872687  
sales-ua@enerpac.com

## Norway

Sales Office Norway  
Unit 524, Nydalsveien 28, 0484 Oslo  
P.O. Box 4814, Nydalen 0422 Oslo, Norway  
Tel: +47 91 578 300  
insidesalesnorway@enerpac.com

## Russia

Rep. office Enerpac  
Russian Federation  
Admirala Makarova Street 8  
125212 Moscow, Russia  
T +7 495 98090 91  
F +7 495 98090 92  
sales-ru@enerpac.com

## Southeast Asia, Hong Kong and Taiwan

Actuant Asia Pte Ltd.  
83 Joo Koon Circle,  
Singapore 629109  
T +65 68 63 0611  
F +65 64 84 5669  
Toll Free:  
T +1800 363 7722  
sales-sg@enerpac.com

## South Korea

Actuant Korea Ltd.  
3Ba 717, Shihwa Industrial Complex  
Jungwang-Dong, Shihung-Shi  
Kyunggi-Do  
Republic of Korea 429-450  
T +82 31 434 4506  
F +82 31 434 4507  
sales-kr@enerpac.com

## Spain and Portugal

ENERPAC SPAIN, S.L.  
Avenida Valdelaparra N° 27 3ª - L8  
28108 Alcobendas (Madrid), Spain  
T +34 91 884 86 06  
F +34 91 884 86 11  
sales-es@enerpac.com

## South Africa and other English speaking African countries

ENERPAC AFRICA (PTY) Ltd.  
Cambridge Office Park, Block E  
5 Bauhinia Avenue  
Highveld Techno Park, Centurion  
Republic of South-Africa  
T 0027 (0) 12 940 0656  
sales-za@enerpac.com

## Sweden, Denmark, Finland and Iceland

Enerpac Scandinavia AB  
Kopparlundsvägen 14,  
721 30 Västerås,  
Sweden  
T +46 (0) 771 415000  
scandinavianinquiries@enerpac.com

## The Netherlands, Belgium, Luxembourg, Central and Eastern Europe, Baltic States, Greece, Turkey and CIS countries

ENERPAC B.V.  
Galvanistraat 115, 6716 AE Ede  
P.O. Box 8097, 6710 AB Ede  
The Netherlands  
T +31 318 535 911  
F +31 318 535 848  
sales-nl@enerpac.com

## United Kingdom and Ireland

ENERPAC Ltd.  
5 Coopies Field  
Morpeth, Northumberland  
NE61 6JR, England  
T +44 1670 5016 50  
F +44 1670 5016 51  
sales-uk@enerpac.com

## USA, Latin America and Caribbean

ENERPAC World Headquarters  
P.O. Box 3241  
Milwaukee, WI 53201-3241 USA  
N86 W12500 Westbrook Crossing  
Menomonee Falls, Wisconsin 53051  
T +1 262 293 1600  
F +1 262 293 7036  
User inquiries:  
+1 800 433 2766  
Distributor inquiries/orders:  
+1 800 558 0530  
+1 800 628 0490  
Technical inquiries:  
techservices@enerpac.com  
sales-us@enerpac.com

**ENERPAC** 



## CONTROLLED TIGHTENING and LOOSENING

**Manual Multipliers  
Square Drive Torque Wrenches  
Hexagon Torque Wrenches**  
Page 4-39



**Electric Torque Wrench Pumps  
Air Driven Torque Wrench Pumps**  
Page 40-55



**Bolt Tensioners  
Tensioning Pumps  
Hoses and Fittings**  
Page 56-60



## JOINT ASSEMBLY and POSITIONING

**Power Box - Portable Tool Sets  
Cylinder-Pump Sets  
Flange Alignment Tools**  
Page 61-64



## JOINT SEPARATION

**Nut Cutters and Nut Splitters  
Flange Spreaders  
Wedgie and Spread Cylinders  
Mechanical Flange Face Tool**  
Page 65-71



## YELLOW PAGES

**Bolting Safety Instructions & Theory  
Tightening and Tensioning  
Hexagon Nut and Bolt Sizes  
Key to Measurement  
Pressure vs. Torque Charts**  
Page 72-85

**Australia and New Zealand**  
Actuant Australia Ltd.  
T +61 297 177 200 – F +61 297 438 648

**Brazil**  
Power Packer do Brasil Ltda.  
T +55 11 5687 2211  
Toll Free: 0800 891 5770

**China**  
Actuant (China) Industries Co.Ltd.  
T +86 0512 5328 7500  
F +86 0512 5335 9690  
Toll Free: T +86 400 885 0369

**Enerpac Integrated Solutions B.V.**  
T +31 74 242 20 45 – F +31 74 243 03 38

**France, Switzerland, North Africa and  
French speaking African countries**  
ENERPAC, Une division d'ACTUANT France S.A.S.  
T +33 1 60 13 68 68 – F +33 1 69 20 37 50

**Germany and Austria**  
Actuant GmbH  
T +49 211 471 490 – F +49 211 471 49 28

**India**  
Actuant India Private Limited  
T +91 80 3928 9000

**Italy**  
ENERPAC S.p.A.  
T +39 02 4861 111 – F +39 02 4860 1288

**Japan**  
Applied Power Japan LTD KK  
T +81 48 662 4911 – F +81 48 662 4955

**Middle East, Egypt and Libya**  
ENERPAC Middle East FZE  
T +971 4 8872686 – F +971 4 8872687

**Norway**  
Tel: +47 91 578 300

**Russia**  
Rep. office Enerpac  
T +7 495 98090 91 – F +7 495 98090 92

**Southeast Asia, Hong Kong and Taiwan**  
Actuant Asia Pte Ltd.  
T +65 68 63 0611 – F +65 64 84 5669  
Toll Free: T +1800 363 7722

**South Korea**  
Actuant Korea Ltd.  
T +82 31 434 4506 – F +82 31 434 4507

**Spain and Portugal**  
ENERPAC SPAIN, S.L.  
T +34 91 884 86 06 – F +34 91 884 86 11

**Sweden, Denmark, Finland and Iceland**  
Enerpac Scandinavia AB  
T +46 (0) 771 415000

**The Netherlands, Belgium, Luxembourg,  
Central and Eastern Europe, Baltic States,  
Greece, Turkey and CIS countries**  
ENERPAC B.V.  
T +31 318 535 911 – F +31 318 535 848

**South Africa and other  
English speaking African countries**  
ENERPAC AFRICA (PTY) Ltd.  
T 0027 (0) 12 940 0656

**United Kingdom and Ireland**  
ENERPAC Ltd.  
T +44 1670 5016 50 – F +44 1670 5016 51

**USA, Latin America and Caribbean**  
ENERPAC  
T +1 262 293 1600 – F +1 262 293 7036

User inquiries: +1 800 433 2766  
Distributor inquiries/orders:  
T +1 800 558 0530 – F +1 800 628 0490

# ENERPAC®



POWERFUL SOLUTIONS. GLOBAL FORCE.

9380 GB © Enerpac 11-2016

Printed in the Netherlands.

"Кристалл Северо-Запад"

www.hydrotool.ru

+7(812)603-29-41

AN  
**Actuant**  
COMPANY