



### DESCRIPTION

Hot Tapping machines available in hydraulic and pneumatic drive options rated to 285 psi. Used for hot tapping from 3" through to 12" with 30" stroke.

### KEY FEATURES

- Small and portable modular design
- 30" stroke
- Capable of drilling 3" – 12" holes (smaller drill sizes optional)
- 285 Psi pressure rating
- Pneumatic or Hydraulic drive options
- Can also be utilized to line stop 4 – 8".
- Auto feed unit optional extra.

### APPLICATIONS

This compact Hot Tapping Machine is designed for pressures up to 285psi, making it ideal for utilities pipelines such as water and gas. The design enables the machine to fit into confined spaces and its manual feed enables safe efficient cutting.

### SPECIFICATIONS

Minimum hole diameter	76mm	3"
	1/2" Twist Drill - 325mm Long	
	1/2" Extended Twist Drill (shell cutter)- 575mm Long	
Maximum hole diameter	305mm	12"
Maximum stroke	762mm	30"
Maximum working pressure	19.7 Bar	285 psi
Temperature min / max	-20 deg F	250 deg F
Connection Flange	3" CLASS 150	
Boring bar diameter	65mm / 2.5"	
Drive motor power	6.0 Kw	8.0 Hp
Air Supply required for peak power @90 psi (6 bar)	1.19 m3/m	42 Scfm
Max Rotation Speed	62 RPM	
Manual feed rate	3.5mm (0.137") per revolution	

### INCLUDED AS STANDARD

Machines are supplied complete with the following items;

LPHT312-H (3-12") Hydraulic Drive	LPHT312 (3-12") Pneumatic Drive
<ul style="list-style-type: none"> <li>✓ Stucchi quick release couplings</li> <li>✓ Gasket</li> <li>✓ Toolkit</li> <li>✓ Front cover protector for transportation</li> <li>✓ Storage / shipping box</li> <li>✓ Pressure test certificate</li> <li>✓ CE certificate</li> <li>✓ Packing list and manual.</li> </ul>	<ul style="list-style-type: none"> <li>✓ Air lubricator kit</li> <li>✓ 2 off gasket seals: 2m x 1m x 4mm</li> <li>✓ Toolkit</li> <li>✓ Front cover protector for transportation</li> <li>✓ Storage / shipping box</li> <li>✓ Pressure test certificate</li> <li>✓ CE certificate</li> <li>✓ Packing list and manual.</li> </ul>

### OPTIONAL ITEMS

Please consider a hydraulic power unit, operator training and accessories listed on page 3.

### SET UP AND OPERATION

The operator must be:

- Trained and conversant with the LPHT312-H..
- Able to identify the correct and incorrect use of static or portable machines.
- Comply with all local and internationally recognised safe use of powered machines.

### WEIGHTS AND LIFTING

In total 4x lifting points are provided on the machine

Machine Weight	77kg	170 lbs
Shipping Weight	122kg	269 lbs

### SHIPPING DIMENSIONS

Length		Width		Height	
cm	inches	cm	inches	cm	inches
144	57	53	21	53	21

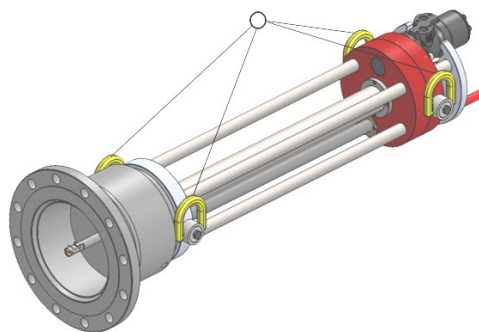

### LPHT3-12 ACCESSORIES

Note: Minimum Valve Size is 2.5"

	Part Number	Description
 <p><b>Cutters</b></p>	LPC-3	3" Low Pressure Hot Tap Cutter - Actual cutter size 2.4" (61.5mm)
	LPC-4	4" Low Pressure Hot Tap Cutter - Actual cutter size 3.4" (86.9mm)
	LPC-6	6" Low Pressure Hot Tap Cutter - Actual cutter size 5.4" (137.7mm)
	LPC-8	8" Low Pressure Hot Tap Cutter - Actual cutter size 7.4" (188.5mm)
	LPC-10	10" Low Pressure Hot Tap Cutter - Actual cutter size 9.4" (239.3mm)
	LPC-12	12" Low Pressure Hot Tap Cutter - Actual cutter size 11.4" (290.1mm)
<p><b>Standard, Extended and Holes Saw Drill Adaptor</b></p>	LPHT312-100	Standard, Extended and Holes Saw Drill Adaptor
 <p><b>Standard Drills from 1/2" to 2"</b></p>	HTMD-1/2"	1/2" Hot Tapping Machine Twist Drill - 325mm Long
	HTMD-5/8"	5/8" Hot Tapping Machine Twist Drill - 347mm Long
	HTMD-3/4"	3/4" Hot Tapping Machine Twist Drill - 349mm Long
	HTMD-7/8"	7/8" Hot Tapping Machine Twist Drill - 363mm Long
	HTMD-1"	1" Hot Tapping Machine Twist Drill - 385mm Long
	HTMD-1-1/8"	1-1/8" Hot Tapping Machine Twist Drill - 393mm Long
	HTMD-1-1/4"	1-1/4" Hot Tapping Machine Twist Drill - 172mm Long
	HTMD-1-7/16"	1-7/16" Hot Tapping Machine Twist Drill - 172mm Long
	HTMD-1-1/2"	1-1/2" Hot Tapping Machine Twist Drill - 172mm Long
	HTMD-1-5/8"	1-5/8" Hot Tapping Machine Twist Drill - 172mm Long
	HTMD-1-3/4"	1-3/4" Hot Tapping Machine Twist Drill - 172mm Long
	HTMD-1-7/8"	1-7/8" Hot Tapping Machine Twist Drill - 172mm Long
	HTMD-2"	2" Hot Tapping Machine Twist Drill - 172mm Long
 <p><b>Extended Drills from 1/2" to 1-1/8"</b></p>	HTMD-1/2"XL	1/2" Extended Hot Tapping Machine Twist Drill - 575mm Long
	HTMD-5/8"XL	5/8" Extended Hot Tapping Machine Twist Drill - 597mm Long
	HTMD-3/4"XL	3/4" Extended Hot Tapping Machine Twist Drill - 624mm Long
	HTMD-7/8"XL	7/8" Extended Hot Tapping Machine Twist Drill - 563mm Long
	HTMD-1"XL	1" Extended Hot Tapping Machine Twist Drill - 585mm Long
	HTMD-1-1/8"XL	1-1/8" Extended Hot Tapping Machine Twist Drill - 593mm Long
 <p><b>Hole Saws</b></p>	HTMHS3	3" Hole Saw - (Actual Size 2-7/8" : 73mm) - 38mm Cut Depth : Starrett Brand Bi-Metal.
	HTMHS4	4" Hole Saw - (Actual Size 3-1/2" : 89mm) - 38mm Cut Depth: Starrett Brand Bi-Metal.
	HTMHS6	6" Hole Saw - (Actual Size 5-1/2" : 140mm) 51mm Cut Depth Starrett Brand Bi-Metal.
 <p><b>Hole Saw Pilot Drills</b></p>	HTMHSP2	Standard (Large) Holesaw Holder & Pilot Drill - 5/8" thread - 75mm long - 32-210mm (1-1/4 - 8-9/32") Ø
	HTMHSP3	Long Series (Large) Holesaw Holder & Pilot Drill - 5/8 thread - 95mm long - 32-210mm (1-1/4 - 8-9/32") Ø
 <p><b>Pilot Drills</b></p>	LPPD-4	3"-4" Low Pressure Pilot Drill
	LPPD-8	6"-8" Low Pressure Pilot Drill
	LPPD-12	10"-12" Low Pressure Pilot Drill
 <p><b>Tap Adaptors</b></p>	150-3FA	3" #150 Flange Adaptor 3" #150 Machine Interface
	150-4FA	4" #150 Flange Adaptor 3" #150 Machine Interface
	150-6FA-4	6" #150 Flange Adaptor 3" #150 Machine Interface
	150-8FA-4	8" #150 Flange Adaptor 3" #150 Machine Interface
	150-10FA-4	10" #150 Flange Adaptor 3" #150 Machine Interface
	150-12FA-4	12" #150 Flange Adaptor 3" #150 Machine Interface