

Shown: WUD-1301E



WU-series

The Economy pump is best suited to power small to medium size fixtures. Its lightweight and compact design makes it ideal for applications which require easy transport of the pump. The universal motor works well on long extension cords.

Heavy on performance, light on weight

- Lightweight and compact design, 12 kg
- Large easy-carry handle for maximum portability
- Two-speed operation reduces cycle times for improved productivity
- 115 VAC 50/60- or 220 VAC 50/60-cycle universal motor will operate on voltage as low as 60 volts
- 24 VDC remote motor control, 3 meters for operator safety
- Starts under full load
- High strength molded shroud with integral handle, protects motor from contamination and damage
- Designed for intermittent duty cycle.

WUD-1100 series

- Provides advance/auto-retract of single-acting cylinders
- 3 meters pendant controls motor and valve operation
- Use with AP-500 accumulator coupler package.

WUD-1300 series

- Provides advance/hold/retract of single-acting cylinders
- 3 meters pendant controls motor and valve operation
- Ideal for applications requiring remote valve operation
- Use with ACBS-22 or ACBS-202 accumulator coupler packages.

Product selection

Model number	Used with cylinder	Pressure rating bar	
		1st stage	2nd stage
WUD-1100B	single-acting	14	350
WUD-1101B	single-acting	14	350
WUD-1100E	single-acting	14	350
WUD-1101E	single-acting	14	350
WUD-1300B	single-acting	14	350
WUD-1301B	single-acting	14	350
WUD-1300E	single-acting	14	350
WUD-1301E	single-acting	14	350

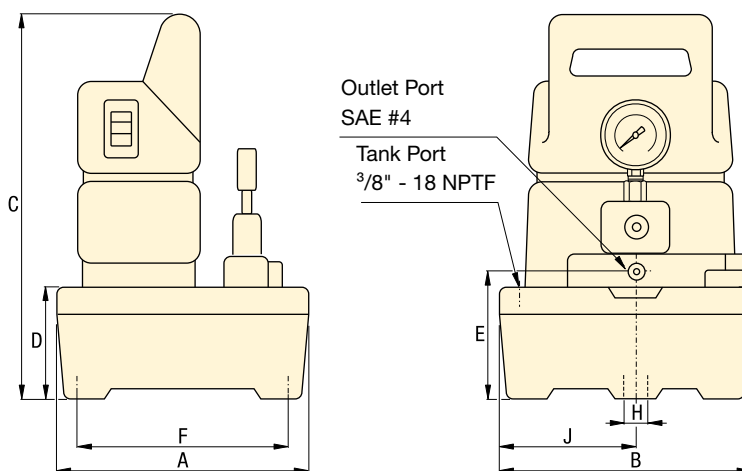
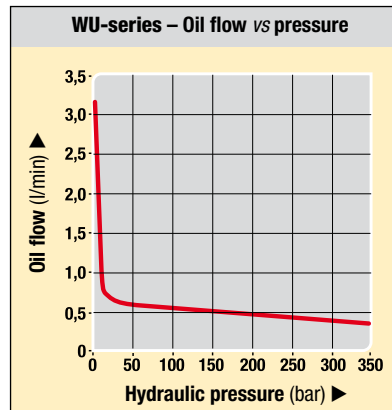

Product dimensions in mm []

Usable oil capacity	Model number	A	B	C	D	E	F	H	J	
litres										kg
1,9	WUD-1100B	244	244	362	102	120	203	10	133	11,8
3,8	WUD-1100B	368	309	374	105	130	324	10	143	15,9
1,9	WUD-1100E	244	244	362	102	120	203	10	133	11,8
3,8	WUD-1100E	368	309	374	105	130	324	10	143	15,9
1,9	WUD-1300B	244	244	362	102	120	203	10	133	11,8
3,8	WUD-1300B	368	309	374	105	130	324	10	143	15,9
1,9	WUD-1300E	244	244	362	102	120	203	10	133	11,8
3,8	WUD-1300E	368	309	374	105	130	324	10	143	15,9

	Output flow rate		Valve type	Current draw	Motor voltage	Sound level	Model number
	1st stage	2nd stage					
	3,28	0,33	Dump*	9,5	115	85	WUD-1100B
	3,28	0,33	Dump*	9,5	115	85	WUD-1101B
	3,28	0,33	Dump*	3,2	230	85	WUD-1100E
	3,28	0,33	Dump*	3,2	230	85	WUD-1101E
	3,28	0,33	Dump and Hold	9,5	115	85	WUD-1300B
	3,28	0,33	Dump and Hold	9,5	115	85	WUD-1301B
	3,28	0,33	Dump and Hold	3,2	230	85	WUD-1300E
	3,28	0,33	Dump and Hold	3,2	230	85	WUD-1301E

* Electric dump valve for auto-retract of cylinders.

- Flow: 0,33 l/min**
- Pressure: 350 bar max**
- Motor: 0,37 kW**
- Reservoir: 1,9 - 3,8 litres**

- E** Bombas eléctricas
- F** Centrale hydraulique
- D** Tauchpumpe

Standard equipment

Gauge, filter and pressure switch



Pumps are supplied with a manifold mounted 400 bar gauge for convenient reading of pump pressure.

A filter at the pressure port helps to protect the pump from contamination.

A manifold mounted adjustable pressure switch provides control of the pump shut-off pressure.

Options

G-series pressure gauges

 190 ▶



Hoses

 192 ▶



FZ-series fittings

 194 ▶



HF-series hydraulic oil

 193 ▶

